

**ARROTOLATORI AUTOMATICI**

**MOTORIZED** MAXI  
TECHNOLOGY REVOLUTION

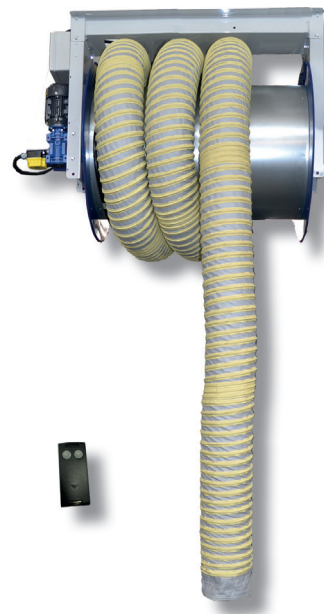

**AUTOMATIC HOSE REELS**

**ENROULEURS AUTOMATIQUE**

**AUTOMATISCHE ABGASSCHLAUCHAUFROLLER**

**ENROLLADORES AUTOMÁTICO**

# AMA-MAXI

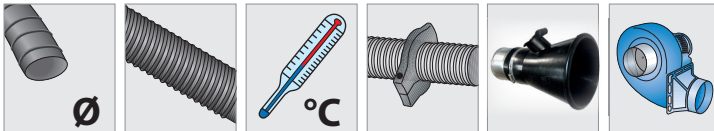

## AMA-MAXI-125/15

125 mm - 5"	15 mt - 50 ft	200° C - 392° F	-	-	1.5 HP - 1.5 Kw
-------------	---------------	-----------------	---	---	-----------------

## AMA-MAXI-125/17

125 mm - 5"	17 mt - 56 ft	200° C - 392° F	-	-	1.5 HP - 1.5 Kw
-------------	---------------	-----------------	---	---	-----------------

## AMA-MAXI-150/13

150 mm - 6"	13 mt - 43 ft	200° C - 392° F	-	-	1.5 HP - 1.5 Kw
-------------	---------------	-----------------	---	---	-----------------

## AMA-MAXI-200/10

200 mm - 8"	10 mt - 32 ft	200° C - 392° F	-	-	1.5 HP - 1.5 Kw
-------------	---------------	-----------------	---	---	-----------------

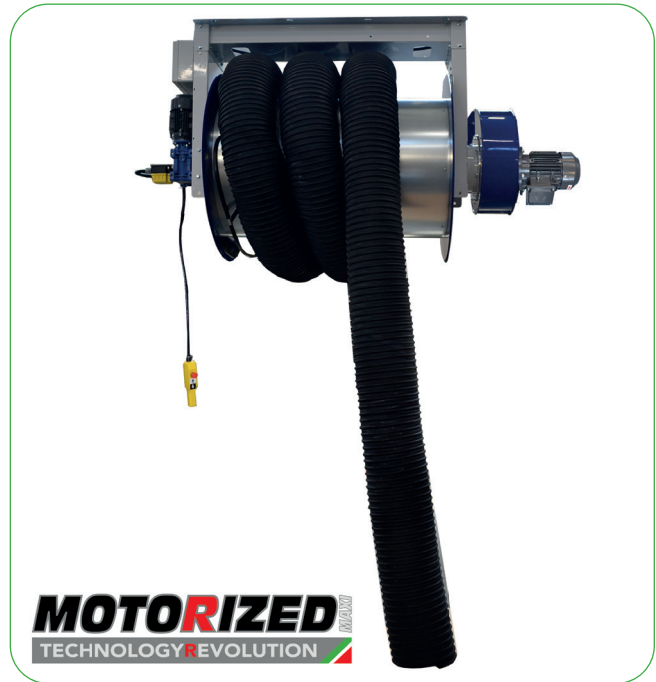
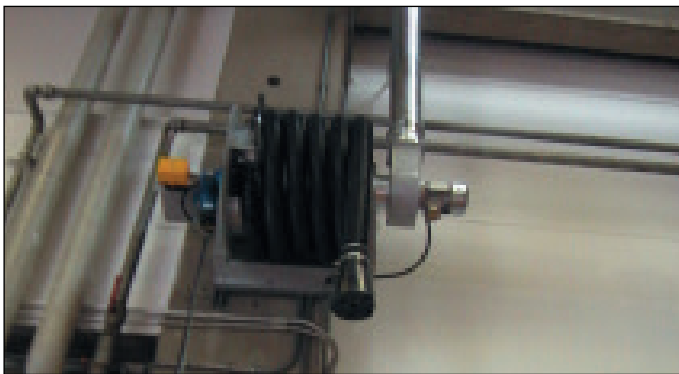

**MOTORIZED**  
TECHNOLOGY REVOLUTION



**Arrotolatore MAXI** dotato di elettroaspiratore e di motorizzazione con pulsantiera per salita e discesa del tubo flessibile di aspirazione. Adatto all'installazione a soffitto e a parete. Completo di fincorsa elettrica di sicurezza e comando remoto di partenza/arresto del ventilatore.



**Motor driven MAXI** hose reel with fan and push button for the roll-up and down of the flexible hose for extraction. Suitable for wall or ceiling installation. Complete with electric safety stop and remote start/stop of the fan.



**Enrouleur MAXI** avec montée et descente électrique du tuyau flexible pour l'aspiration des gaz d'échappement avec ventilateur et câble. Installation au mur et au plafond. Equipé d'une fin de course de sécurité qui fonctionne pour le démarrage du ventilateur.



**Abgasschlauchaufroller MAXI** für die Montage an der Wand oder Decke komplett mit Motorantrieb, Ventilator und Kabelbedienung funktion Auf- Abrollen des Schläuches und Ein- Ausschalten des Ventilators. Komplett mit elektrischem Schlauchstopper



**Enrollador MAXI**, motorizado para el rebobinado automático de la manguera. Dispositivo de control del rebobinado con cable. Puede ser montado en techo o pared. Esta equipado con un 'fin de carrera' eléctrico, que también sirve para el encendido automático del aspirador.

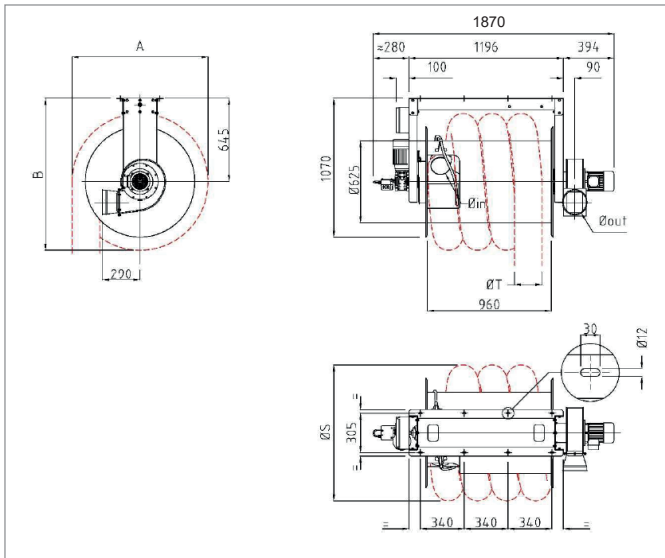

Mod	A (mm)	B (mm)	S Ø (mm)	T Ø EXT. (mm)	IN Ø (mm)	Fan	OUT Ø (mm)	Kw - Hp	Kw	Kg*	Kg tot**
AMA-MAXI-125/15	907	1098.5	907	141	125	AL-150	180	1.1/1.5	0,25	101	124
AMA-MAXI-125/15-D	907	1098.5	907	141	125	AL-150	160	1.1/1.5	0,25	101	124
AMA-MAXI-125/17	907	1098.5	907	141	125	AL-150	180	1.1/1.5	0,25	101	126
AMA-MAXI-125/17-D	907	1098.5	907	141	125	AL-150	160	1.1/1.5	0,25	101	126
AMA-MAXI-150/13	957	1123.5	907	166	150	AL-150	180	1.1/1.5	0,25	101,5	125
AMA-MAXI-150/13-D	957	1123.5	907	166	150	AL-150	160	1.1/1.5	0,25	101,5	125
AMA-MAXI 200/10	1053	1171.5	1053	214	200	AL-150	180	1.1/1.5	0,25	102	127
AMA-MAXI 200/10-D	1053	1171.5	1053	214	200	AL-150	160	1.1/1.5	0,25	102	127

\*Peso relativo all'arrotolatore SENZA tubazione flessibile e bocchetta - Weight of the retractor WITHOUT hose and nozzle - Poids de l'enrouleur SANS tuyau ni buse - Gewicht des Aufrollers OHNE Schlauch und Düse - El peso del retractor SIN manguera ni boquilla.

\*\*Peso relativo all'arrotolatore in versione "COMP" - Weight of the reel in "COMP" version - Poids de la bobine en version "COMP" - Gewicht der Spule in "COMP"-Version - El peso del carrete en la versión "COMP".



# AM-MAXI-200/10-HT

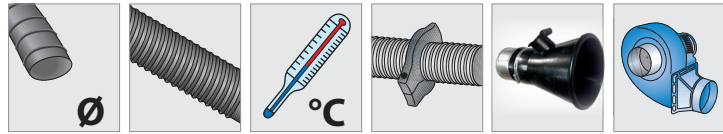

AM-MAXI-200/10-HT					
200 mm - 8"	10 mt - 32 ft	1000° C - 1832° F	-	-	-

 Arrotolatore MAXI dotato di motorizzazione e pulsantiera per salita e discesa del tubo flessibile di aspirazione alta temperatura. Adatto all'installazione a soffitto e a parete. Completo di fine-corsa elettrico di sicurezza e comando remoto di partenza/arresto del ventilatore (centralizzato). Versione per alte Temperature.

 Motor driven MAXI hose reel with push button for the roll-up and down of the flexible hose for extraction. Suitable for wall or ceiling installation. Complete with electric safety stop and remote start/stop of the centralized fan. High temperature version.

 Enrouleur MAXI avec monté et descente électrique avec câble pour tuyau flexible pour l'aspiration des gaz d'échappement. Installation au mur et au plafond. Equipé d'une fin de course de sécurité qui fonctionne pour le démarrage du ventilateur centralisé. Version haute température.

 Abgasschlauchaufroller MAXI für die Montage an der Wand oder Decke komplett mit Motorantrieb und Kabelbedienung funktion Auf- Abrollen des Schläuches und Ein- Ausschalten des Ventilators für eine Zentralanlage. Komplett mit elektrischem Schlauchstopper. Version für hohe Temperaturen.

 Enrollador MAXI, motorizado para el rebobinado automático de la manguera. Dispositivo de control de rebobinado con cable. Puede ser montado en techo o pared. Esta equipado con un 'fin de carrera' eléctrico, que también sirve para el encendido automático del aspirador en instalaciones centralizadas. Versión de alta temperatura.

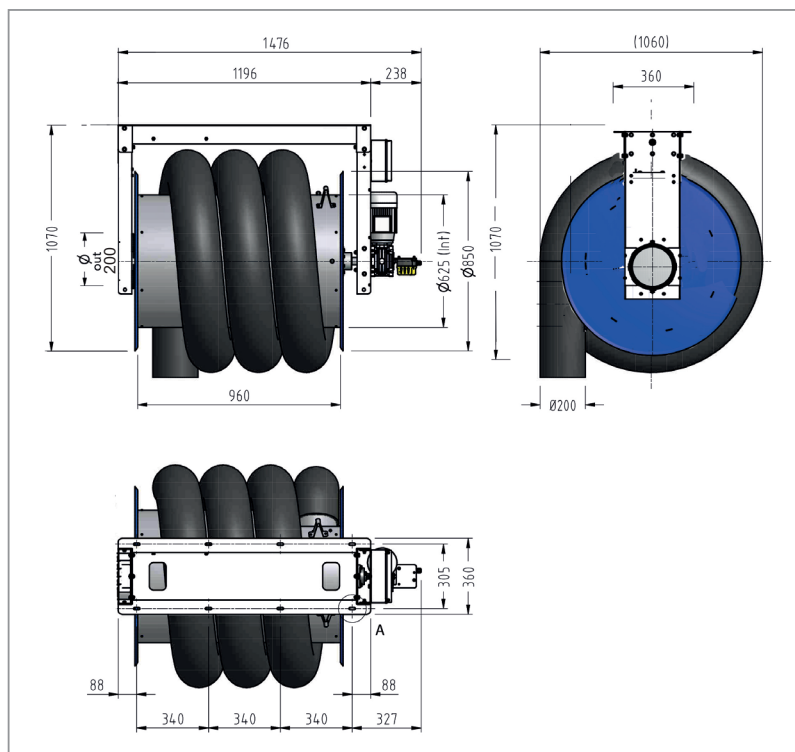

# AMA-MAXI-200/10-HT

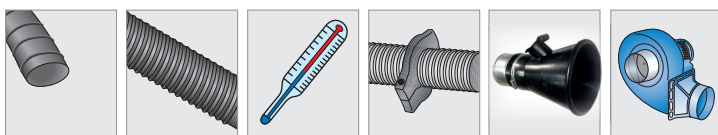

AMA-MAXI-200/10-HT

200 mm - 8"	10 mt - 32 ft	1000° C - 1832° F	-	-	3 HP - 2.2 Kw
-------------	---------------	-------------------	---	---	---------------



Arrotolatore MAXI dotato di elettroaspiratore e di motorizzazione con pulsantiera per salita e discesa del tubo flessibile di aspirazione. Adatto all'installazione a soffitto e a parete. Completo di fincorsa elettrico di sicurezza e comando remoto di partenza/arresto del ventilatore. Versione per alte Temperature.



Motor driven MAXI hose reel with fan and push button for the roll-up and down of the flexible hose for extraction. Suitable for wall or ceiling installation. Complete with electric safety stop and remote start/stop of the fan. High temperature version.



Enrouleur MAXI avec monté et descente électrique du tuyau flexible pour l'aspiration des gaz d'échappement avec ventilateur et câble. Installation au mur et au plafond. Equipé d'une fin de course de sécurité qui fonctionne pour le démarrage du ventilateur. Version haute température.



Abgasschlauchaufroller MAXI für die Montage an der Wand oder Decke komplett mit Motorantrieb, Ventilator und Kabelbedienung funktion Auf- Abrollen des Schläuches und Ein- Ausschalten des Ventilators. Komplett mit elektrischem Schlauchstopper. Version für hohe Temperaturen.



Enrollador MAXI, motorizado para el rebobinado automático de la manguera. Dispositivo de control del rebobinado con cable. Puede ser montado en techo o pared. Esta equipado con un 'fin de carrera' eléctrico, que también sirve para el encendido automático del aspirador. Versión de alta temperatura.

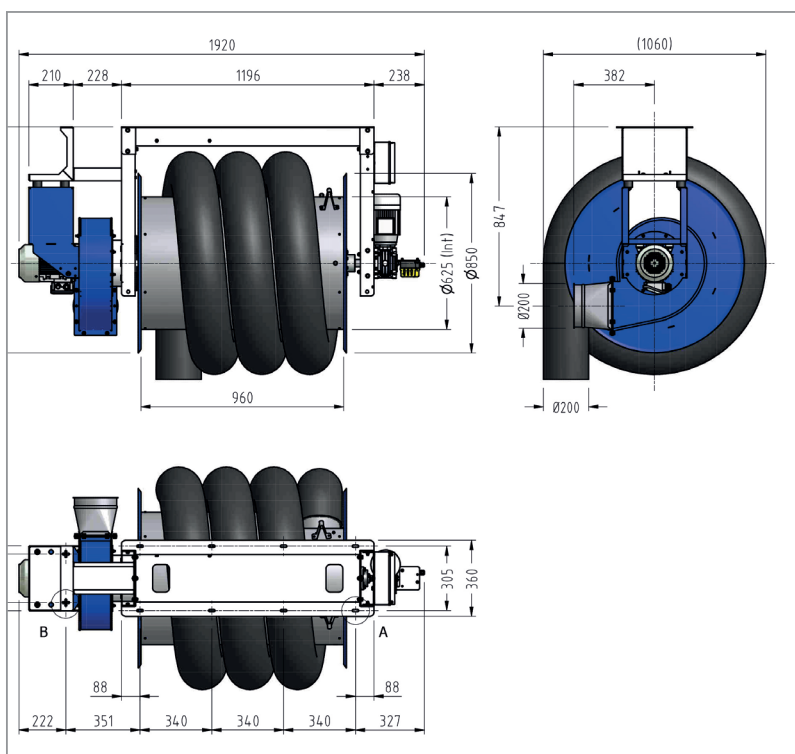

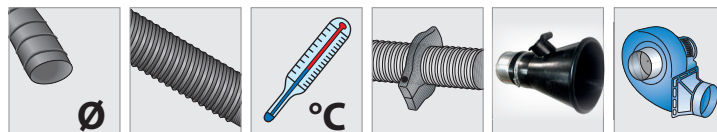
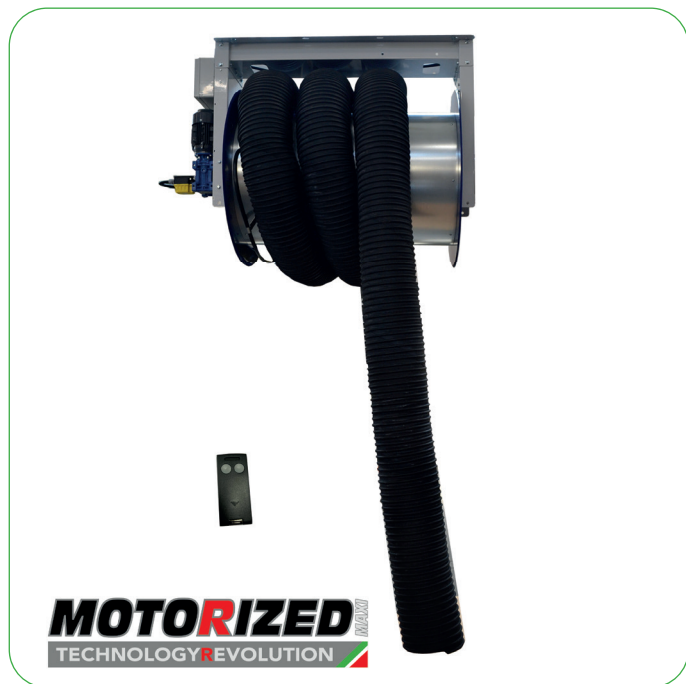



AMT-MAXI-125/15D					
125 mm - 5"	15 mt - 50 ft	200° C - 392° F	-	-	-
AMT-MAXI-125/ 17D					
125 mm - 5"	17 mt - 56 ft	200° C - 392° F	-	-	-
AMT-MAXI-150/13D					
150 mm - 6"	13 mt - 43 ft	200° C - 392° F	-	-	-
AMT-MAXI-200/10D					
200 mm - 8"	10 mt - 32 ft	200° C - 392° F	-	-	-



 Arrotolatore MAXI dotato di motorizzazione con telecomando per salita e discesa del tubo flessibile di aspirazione. Adatto all'installazione a soffitto e a parete. Completo di finecorsa elettrico di sicurezza e comando remoto di partenza/arresto del ventilatore (centralizzato).

 Motor driven MAXI hose reel with remote control for the roll-up and down of the flexible hose for extraction. Suitable for wall or ceiling installation. Complete with electric safety stop and remote start/stop of the centralized fan.

 Enrouleur MAXI avec montée et descente électrique du tuyau flexible pour l'aspiration des gaz d'échappement avec radio-commande. Installation au mur et au plafond. Equipé d'une fin de course de sécurité qui fonctionne pour le démarrage du ventilateur centralisé.

 Abgasschlauchaufroller MAXI für die Montage an der Wand oder Decke komplett mit Motorantrieb und Fernbedienung funktion Auf- Abrollen des Schläuches und Ein- Ausschalten des Ventilators für eine Zentralanlage. Komplett mit elektrischem Schlauchstopper

 Enrollador MAXI, motorizado para el rebobinado automático de la manguera. Mando a distancia para el control del rebobinado. Puede ser montado en techo o pared. Esta equipado con un 'fin de carrera' eléctrico, que también sirve para el encendido automático del aspirador en instalaciones centralizadas.

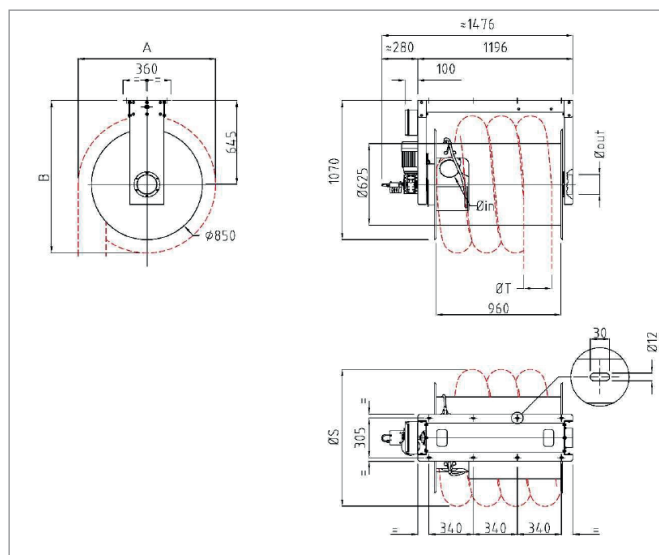

\*Peso relativo all'arrotolatore SENZA tubazione flessibile e bocchetta - Weight of the retractor WITHOUT hose and nozzle - Poids de l'enrouleur SANS tuyau ni buse - Gewicht des Aufrollers OHNE Schlauch und Düse - El peso del retractor SIN manguera ni boquilla.

\*\*Peso relativo all'arrotolatore in versione "COMP" - Weight of the reel in "COMP" version - Poids de la bobine en version "COMP" - Gewicht der Spule in "COMP"-Version - El peso del carrete en la versión "COMP".

Mod	A (mm)	B (mm)	S Ø (mm)	T Ø EXT. (mm)	IN Ø (mm)	OUT Ø (mm)	Kw	Kg*	Kg tot**
AMT-MAXI-125/15	907	1098.5	907	141	125	150	0,25	83	106
AMT-MAXI-125/15-D	907	1098.5	907	141	125	150	0,25	83	106
AMT-MAXI-125/17	907	1098.5	907	141	125	150	0,25	83	108
AMT-MAXI-125/17-D	907	1098.5	907	141	125	150	0,25	83	108
AMT-MAXI-150/13	957	1123.5	907	166	150	150	0,25	83,5	107
AMT-MAXI-150/13-D	957	1123.5	907	166	150	150	0,25	83,5	107
AMT-MAXI 200/10	1053	1171.5	1053	214	200	200	0,25	84	109
AMT-MAXI 200/10-D	1053	1171.5	1053	214	200	200	0,25	84	109

# AMTA-MAXI

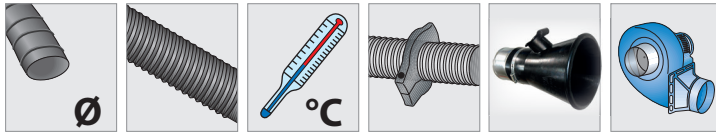

AMTA-MAXI-125/15-SB					
125 mm - 5"	15 mt - 50 ft	200° C - 392° F	-	-	1.5 HP - 1.1 Kw

AMTA-MAXI-125/ 17-SB					
125 mm - 5"	17 mt - 56 ft	200° C - 392° F	-	-	1.5 HP - 1.1 Kw

AMTA-MAXI-150/13-SB					
150 mm - 6"	13 mt - 43 ft	200° C - 392° F	-	-	1.5 HP - 1.1 Kw

AMTA-MAXI-200/10-SB					
200 mm - 8"	10 mt - 32 ft	200° C - 392° F	-	-	1.5 HP - 1.1 Kw



 Arrotolatore MAXI dotato di elettroaspiratore e di motorizzazione con telecomando per salita e discesa del tubo flessibile di aspirazione. Adatto all'installazione a soffitto e a parete. Completo di fincorsa elettrico di sicurezza e comando remoto di partenza/arresto del ventilatore.

 Motor driven MAXI hose reel with fan and remote control for the roll-up and down of the flexible hose for extraction. Suitable for wall or ceiling installation. Complete with electric safety stop and remote start/stop of the fan.

 Enrouleur MAXI avec montée et descente électrique du tuyau flexible pour l'aspiration des gaz d'échappement avec ventilateur et radio-commande. Installation au mur et au plafond. Equipé d'une fin de course de sécurité qui fonctionne pour le démarrage du ventilateur centralisé.

 Abgasschlauchaufroller MAXI für die Montage an der Wand oder Decke komplett mit Motorantrieb, Ventilator und Fernbedienung funktion Auf- Abrollen des Schläuches und Ein- Ausschalten des Ventilators. Komplett mit elektrischem Schlauchstopper.

 Enrollador MAXI, motorizado para el rebobinado automático de la manguera, y con aspirador. Mando a distancia para el control del rebobinado. Puede ser montado en techo o pared. Esta equipado con un 'fin de carrera' eléctrico, que también sirve para el encendido automático del aspirador.

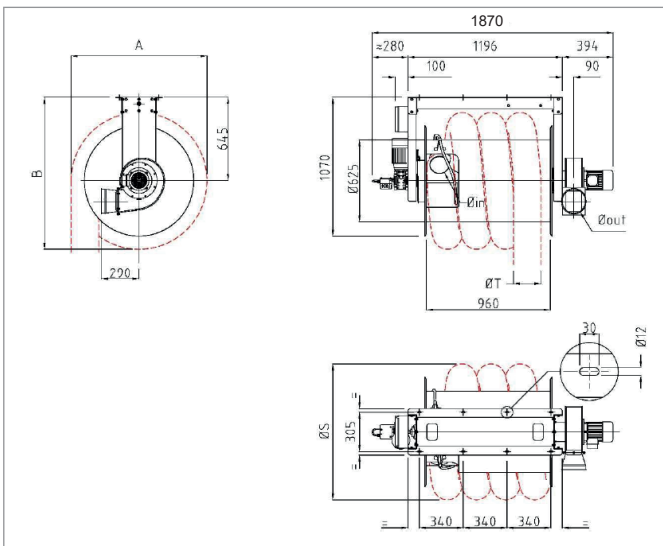

Mod	A (mm)	B (mm)	S Ø (mm)	T Ø EXT. (mm)	IN Ø (mm)	Fan	OUT Ø (mm)	Kw - Hp	Kw	Kg*	Kg tot**
AMTA-MAXI-125/15	907	1098.5	907	141	125	AL-150	180	1.1/1.5	0,25	101	124
AMTA-MAXI-125/15-D	907	1098.5	907	141	125	AL-150	160	1.1/1.5	0,25	101	124
AMTA-MAXI-125/17	907	1098.5	907	141	125	AL-150	180	1.1/1.5	0,25	101	126
AMTA-MAXI-125/17-D	907	1098.5	907	141	125	AL-150	160	1.1/1.5	0,25	101	126
AMTA-MAXI-150/13	957	1123.5	907	166	150	AL-150	180	1.1/1.5	0,25	101,5	125
AMTA-MAXI-150/13-D	957	1123.5	907	166	150	AL-150	160	1.1/1.5	0,25	101,5	125
AMTA-MAXI 200/10	1053	1171.5	1053	214	200	AL-150	180	1.1/1.5	0,25	102	127
AMTA-MAXI 200/10-D	1053	1171.5	1053	214	200	AL-150	160	1.1/1.5	0,25	102	127

\*Peso relativo all'arrotolatore SENZA tubazione flessibile e bocchetta - Weight of the retractor WITHOUT hose and nozzle - Poids de l'enrouleur SANS tuyau ni buse - Gewicht des Aufrollers OHNE Schlauch und Düse - El peso del retractor SIN manguera ni boquilla.





\*\*Peso relativo all'arrotolatore in versione "COMP" - Weight of the reel in "COMP" version - Poids de la bobine en version "COMP" - Gewicht der Spule in "COMP"-Version - El peso del carrete en la versión "COMP".

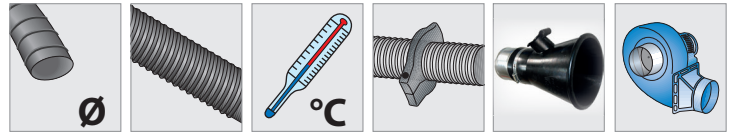

**MOTORIZED**  
TECHNOLOGY REVOLUTION



AMT-MAXI-200/10-HT					
200 mm - 8"	10 mt - 32 ft	1000° C - 1832° F	-	-	-

-  Arrotolatore MAXI dotato di motorizzazione con telecomando per salita e discesa del tubo flessibile di aspirazione. Adatto all'installazione a soffitto e a parete. Completo di fincorsa elettrico di sicurezza e comando remoto di partenza/arresto del ventilatore (centralizzato). Versione per alte Temperature.
-  Motor driven MAXI hose reel with remote control for the roll-up and down of the flexible hose for extraction. Suitable for wall or ceiling installation. Complete with electric safety stop and remote start/stop of the centralized fan. High temperature version.
-  Enrouleur MAXI avec monté et descente électrique du tuyau flexible pour l'aspiration des gaz d'échappement avec radio-commande. Installation au mur et au plafond. Equipé d'une fin de course de sécurité qui fonctionne pour le démarrage du ventilateur centralisé. Version haute température.
-  Abgasschlauchaufroller MAXI für die Montage an der Wand oder Decke komplett mit Motorantrieb und Fernbedienung funktion Auf- Abrollen des Schläuches und Ein- Ausschalten des Ventilators für eine Zentralanlage. Komplet mit elektrischem Schlauchstopper. Version für hohe Temperaturen.
-  Enrollador MAXI, motorizado para el rebobinado automático de la manguera. Mando a distancia para el control del rebobinado. Puede ser montado en techo o pared. Esta equipado con un 'fin de carrera' eléctrico, que también sirve para el encendido automático del aspirador en instalaciones centralizadas. Versión de alta temperatura.

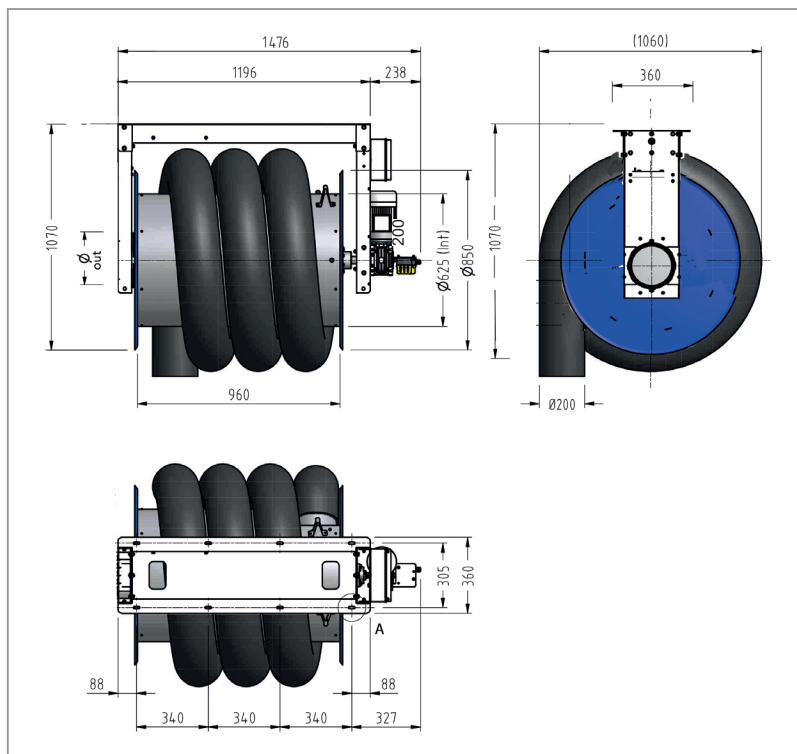

# AMTA-MAXI-200/10-HT

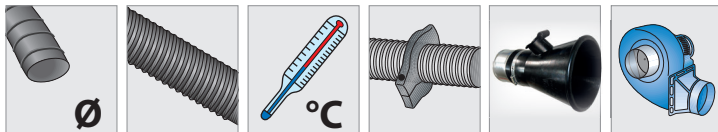

AMTA-MAXI-200/10-HT					
200 mm - 8"	10 mt - 32 ft	1000° C - 1832° F	-	-	3 HP - 2.2 Kw

 Arrotolatore MAXI dotato di elettroaspiratore e di motorizzazione con telecomando per salita e discesa del tubo flessibile di aspirazione. Adatto all'installazione a soffitto e a parete. Completo di fincorsa elettrico di sicurezza e comando remoto di partenza/arresto del ventilatore. Versione per alte Temperature.

 Motor driven MAXI hose reel with fan and remote control for the roll-up and down of the flexible hose for extraction. Suitable for wall or ceiling installation. Complete with electric safety stop and remote start/stop of the fan. High temperature version.

 Enrouleur MAXI avec monté et descente électrique du tuyau flexible pour l'aspiration des gaz d'échappement avec ventilateur et radio-commande. Installation au mur et au plafond. Equipé d'une fin de course de sécurité qui fonctionne pour le démarrage du ventilateur centralisé. Version haute température.

 Abgasschlauchaufroller MAXI für die Montage an der Wand oder Decke komplett mit Motorantrieb, Ventilator und Fernbedienung funktion Auf- Abrollen des Schläuches und Ein- Ausschalten des Ventilators. Komplett mit elektrischem Schlauchstopper. Version für hohe Temperaturen.

 Enrollador MAXI, motorizado para el rebobinado automático de la manguera, y con aspirador. Mando a distancia para el control del rebobinado. Puede ser montado en techo o pared. Esta equipado con un 'fin de carrera' eléctrico, que también sirve para el encendido automático del aspirador. Versión de alta temperatura.

