

BOCCHETTE



NOZZLES
ENTONNOIR
TRICHTER
BOQUEREL

BGPG - BGPM



BGTPG

-  Bocchetta in gomma con pinza "GRIP" con tampone e ingresso sonda per C.O. (Ø 32 mm).
-  Rubber nozzle with GRIP clamp, rubber buffer and C.O. (Ø 32 mm) probe inlet.
-  Entonnoir en caoutchouc avec pince "GRIP", tampon et entrée sonde pour C.O. (Ø 32 mm).
-  Trichter mit "Grip" Klemme und mit C.O. Sondeanschluss C.O. (Ø 32 mm).
-  Boquerel cónico en goma anti-arañazos con toma para sonda (Ø 32 mm), rejilla anti intrusión y pinza con tampón en goma anti-arañazos con bloqueo manual.

Model	for hose Ø mm	suction inlet Ø mm
BGTPG-75/140	75	140
BGTPG-100/140	100	140



BGPM

-  Bocchetta in gomma con pinza manuale e ingresso sonda per C.O. (Ø 32 mm).
-  Rubber nozzle with manual locking gripper and intake for C.O. (Ø 32 mm).
-  Entonnoir en caoutchouc avec prise à blocage manuel et prise C.O (Ø 32 mm).
-  Gummitrichter mit Handsperrklemmzange und Eingang für C.O. (DN 32 mm).
-  Boquerel de goma con pinza de bloqueo manual, y toma de CO. (Ø 32 mm).

Model	for hose Ø mm	suction inlet Ø mm
BG-75/140-PM	75	140
BG-100/140-PM	100	140
BG-125/140-PM	125	140
BG-100/200-PM	100	200
BG-125/200-PM	125	200
BG-150/200-PM	150	200
BG-200/200-PM	200	200

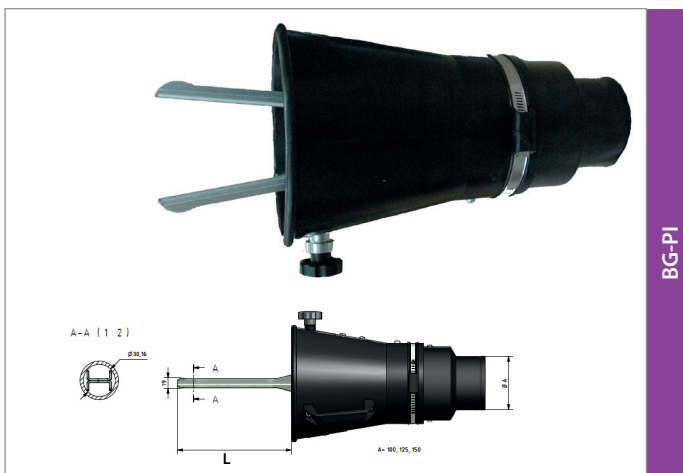

BG-PI

-  Bocchetta in gomma per scarichi integrati nel paraurti dotato di pinza interna e ingresso sonda per C.O. (Ø 32 mm).
-  Rubber nozzle for hidden exhaust pipes, equipped with internal gripper and intake for C.O. (Ø 32 mm).
-  Entonnoir en caoutchouc pour échappements intégrés dans le pare-chocs, équipée avec pince interne et prise C.O (Ø 32 mm).
-  Gummitrichter mit Anschluss für C.O. (DN 32 mm) und Innen Klemmzange für Auspuffe in der Stoßstange integriert.
-  Boquerel en goma para tubos de escape integrados en el parachoque, con pinza interna y toma de CO. (Ø 32 mm).

Model	for hose Ø mm	suction inlet Ø mm	L
BG-075/200-PI	75	200	215
BG-100/200-PI	100	200	215
BG-125/200-PI	125	200	215
BG-150/200-PI	150	200	215
BG-200/200-PI	200	200	215
BG-075/200-PI-LC	75	200	140
BG-100/200-PI-LC	100	200	140
BG-125/200-PI-LC	125	200	140
BG-150/200-PI-LC	150	200	140
BG-200/200-PI-LC	200	200	140



BGL-PI

-  Bocchetta in gomma per scarichi integrati nel paraurti dotato di pinza interna e ingresso sonda per C.O. (Ø 32 mm). Allestita con gomma anteriore antigraffio.
-  Rubber nozzle for hidden exhaust pipes, equipped with internal gripper and intake for C.O. (Ø 32 mm). Equipped with front anti-scratch rubber.
-  Entonnoir en caoutchouc pour échappements intégrés dans le pare-chocs, équipée avec pince interne et prise C.O (Ø 32 mm). Équipé avec du caoutchouc sur l'avant résistant aux rayures.
-  Gummitrichter mit Anschluss für C.O. (DN 32 mm) und Innen Klemmzange für Auspuffe in der Stoßstange integriert. Beliefert mit Gummischutz vorne.
-  Boquerel en goma para tubos de escape integrados en el parachoque, con pinza interna y toma de CO. (Ø 32 mm). Equipada con caucho anterior antirrayas.

Model	for hose Ø mm	suction inlet Ø mm	L
BGL-075/200-PI	75	200	215
BGL-100/200-PI	100	200	215
BGL-125/200-PI	125	200	215
BGL-150/200-PI	150	200	215
BGL-200/200-PI	200	200	215



BGA

 Bocchetta ovale in gomma per scarichi sdoppiati con ingresso sonda per C.O. (Ø 32 mm).

 Oval rubber nozzle for double exhausts with intake for C.O. (Ø 32 mm).

 Entonnoir en caoutchouc pour pots d'échappement doubles avec prise C.O. (Ø 32 mm).

 Gummitrichter Oval für Doppelauspuffe und mit Anschluss für C.O. (DN 32 mm).

 Boquerel oval de goma para dobles tubos de escape, con toma de CO (Ø 32 mm).

Model	for hose Ø mm	suction inlet Ø mm
BGA-75	75	165x88
BGA-100	100	165x88





BGA-PM

 Bocchetta ovale in gomma per scarichi sdoppiati pinza manuale e ingresso sonda per C.O. (Ø 32 mm).

 Oval rubber nozzle for double exhausts with manual locking gripper and intake for C.O. (Ø 32 mm).

 Entonnoir en caoutchouc pour pot d'échappement double avec prise à blocage manuel et prise C.O (Ø 32 mm).

 Gummitrichter Oval mit Klemmzange für Doppelauspuffe und mit Anschluss für C.O. (DN 32 mm).

 Boquerel oval de goma para dobles tubos de escape, con pinza "Filcar" de bloqueo manual, y toma de CO. (Ø 32 mm).

Model	for hose Ø mm	suction inlet Ø mm
BGA-75-PM	75	165x88
BGA-100-PM	100	165x88





BGA-PGI

 Bocchetta ovale in gomma con pinza interna di fissaggio con tamponi in gomma alle estremità e ingresso sonda per C.O. (Ø 32 mm).

 oval rubber nozzle with internal clamp with rubber buffer and C.O. (Ø 32 mm) probe inlet.

 Entonnoir ovale en caoutchouc avec pince interne de fixation, avec tampons en caoutchouc aux niveaux des extrémités et entrée sonde pour C.O. (Ø 32 mm).

 Ovaler Trichter mit Zange fuer Innenklemmung und C.O. Sondeanschluss (DN 32 mm).

 Boquerel ovalado en goma anti-arañazos con alicata interno de bloqueo manual, tampones en goma laterales y toma para sonda (Ø 32 mm).

Model	for hose Ø mm	suction inlet Ø mm
BGA-75-PGI	75	165x88
BGA-100-PGI	100	165x88



BO-T-HO

BO-T-HO

 Bocchetta in alluminio ed acciaio adatto per autocarri, impiego fisso e mobile. Dotato di pinza interna protezione in gomma su tutti i bordi che vengono a contatto con le parti applicate. Disponibile con pinza centrale ed in versione Alta Temperatura (HT) o Bassa Temperatura (LT).

 Aluminium and iron nozzle suitable for trucks, fix and mobile use, with internal gripper; Rubber protection in all the edges. Available with central plier and with high Temperatur (HT) or low temperature (LT) version

 Entonnoir en aluminium et acier adapte pour camions, emploi fixe et mobile. Equipée avec pince interne. Protection en caoutchouc sur tous les bords qui sont en contact avec les parties appliquées. Disponible avec pince central et en version Haute Température (HT) ou Basse Température (LT)

 Stahl- Alutrichter fuer LKW. mit Innenzange ausgestattet. Gummischutz auf jeder Kante. Verfügbar mit Zentrale Griff und mit Hohe Temperatur (HT) oder Niedrige Temperatur (LT) Version

 Boquerel en aluminio y acero apta para autocares para uso fijo o portable, con pinza interna. E Goma de proteccion en todos los lados en contacto con la aplicacion. Disponible con pinza central y en versión Alta Temperatura (HT) o Baja Temperatura (LT).

Model	for hose Ø mm	suction inlet Ø mm
BO-T-100/PI-HO-LT	100	340x180
BO-T-100/PI-HO-HT	100	340x180
BO-T-125/PI-HO-LT	125	340x180
BO-T-125/PI-HO-HT	125	340x180
BO-T-150/PI-HO-LT	150	340x180
BO-T-150/PI-HO-HT	150	340x180
BO-T-200/PI-HO-LT	200	340x180
BO-T-200/PI-HO-HT	200	340x180

BGA - BGP - BO-T-FUMOSTOP





BOT-/PI-S

 Bocchetta in alluminio ed acciaio adatto per autocarri, impiego fisso e mobile. Dotato di pinza interna protezione in gomma su tutti i bordi che vengono a contatto con le parti applicate. Disponibile con pinza laterale ed in versione Alta Temperatura (HT) o Bassa Temperatura (LT).

 Aluminium and iron nozzle suitable for trucks, fix and mobile use, with internal gripper; Rubber protection in all the edges. Available with one side plier and with high Temperatur (HT) or low temperature (LT) version.

 Entonnoir en aluminium et acier adapte pour camions, emploi fixe et mobile. Equipée avec pince interne. Protection en caoutchouc sur tous les bords qui sont en contact avec les parties appliquées.

 Stahl- Alutrichter fuer LKW. mit Innenzange ausgestattet. Gummischutz auf jeder Kante. : Verfügbar mit seitlichem Griff und mit Hohe Temperatur (HT) oder Niedrige Temperatur (LT) Version

 Boquerel en aluminio y acero apta para autocares para uso fijo o portable, con pinza interna. E Goma de proteccion en todos los lados en contacto con la aplicacion. Disponible con pinza lateral y en versión Alta Temperatura (HT) o Baja Temperatura (LT).

Model	for hose Ø mm	suction inlet Ø mm
BOT-100/PI-S-LT	100	340x180
BOT-100/PI-S-HT	100	340x180
BOT-125/PI-S-LT	125	340x180
BOT-125/PI-S-HT	125	340x180
BOT-150/PI-S-LT	150	340x180
BOT-150/PI-S-HT	150	340x180
BOT-200/PI-S-LT	200	340x180
BOT-200/PI-S-HT	200	340x180





BOT-E06-MRET

 Bocchetta in alluminio ed acciaio adatto per autocarri, impiego fisso e mobile. Struttura di supporto regolabile in altezza e lunghezza. Protezione in gomma su tutti i bordi che vengono a contatto con le parti applicate. Hmax 975, Pmax230, L705.

 Aluminium and iron nozzle suitable for trucks, fix and mobile use; support structure adjustable in height and length. Rubber protection in all the edges. Height max 975mm, depth max 230mm, length max 705mm.

 Entonnoir en aluminium et acier adapte pour camions, emploi fixe et mobile. Structure du support réglable en hauteur et longueur. Protection en caoutchouc sur tous les bords qui sont en contact avec les parties appliquées. Hmax 975, Pmax230, L705.

 Stahl- Alutrichter fuer LKW. Hoehe Laenge verstellbar. Gummischutz auf jeder Kante. Hoehe max 975, Tiefe max230, Laenge 705.

 Boquerel en aluminio y acero apta para autocares para uso fijo o portable. Estructura con soporte ajustable en altura y longitud. Goma de proteccion en todos los lados en contacto con la aplicacion . Hmax 975, Pmax230, L705.

Model	for hose Ø mm
BOT-150/E06-MRET	150





BOT-E06-MTUB

 Bocchetta per veicoli industriali, resistenza termica a 200°C, cateni di sicurezza e impugnatura su entrambe le estremità del flessibile.

 Industrial vehicle, thermal resistance 200°, safety chain and handle on both sides of the flexible hose.

 Entonnoir pour véhicules industriels, résistance thermique à 200°C, chaînes de sécurité et poignées sur les deux extrémités du flexible.

 Trichter fuer Lastwagen, bis 200 °C Beständig, mit Sicherheitsketten und Griffe auf der Schlauch.

 Boquerel apta para vehiculos industriales, resistente hasta 200°C, cadenas de seguridad y manillas flexibles en ambos lados.

Model	for hose Ø mm	suction inlet Ø mm	L mt
BOT-E06-MTUB	150	200	2



FUMOSTOP-BGT/BGA

 Bocchetta compresa di filtro con carboni attivi per gas di scarico e ingresso sonda per C.O. (Ø 32 mm).

 Nozzle complete with active coal filter for exhaust gas and C.O. (Ø 32 mm) probe inlet.

 Entonnoir avec filtre à charbon actif pour le gaz d'échappement et entrée sonde pour C.O. (Ø 32 mm).

 Trichter mit Aktivkohle fuer Abgase mit C.O. Sondanschluss (DN 32 mm).

 Boquerel con filtros de carbonos activos para gases de escape y toma para sonda (Ø 32 mm).

Model	suction inlet Ø mm
FUMOSTOP-BGT	140
FUMOSTOP-BGA	140
FUMOSTOP-BGPG	165x88
FUMOSTOP-BGA-PM	165x88





BRM

 Bocchetta con cono in gomma BG montato su asta regolabile verticalmente e dotato di dispositivo di inclinazione.

 Nozzle with rubber cone BG mounted on stand with vertical adjusting rod and inclination device.

 Entonnoir avec cône en caoutchouc BG monté sur pied avec régulation verticale et dispositif d'inclinaison.

 Höhenverstellbarer BG Gummitrichter mit Stativ.

 Boquerel BG con sistema de inclinación, y con asta de regulación en altura.

Model	for hose Ø mm	suction inlet Ø mm
BRM-75	75	140
BRM-75/200	75	200
BRM-100	100	200
BRM-125	125	200
BRM-150	150	200





BC-AUIII

 Bocchetta in acciaio inox montata su carrello con ingresso sonda C.O. e doppia asta di regolazione.

 Trolley mounted stainless steel nozzle with C.O. intake and double adjusting rod.

 Entonnoir en acier inox monté sur chariot, avec prise C.O et double régulation de position.

 Edelstahltrichter komplett mit einem Wagen und Stativ. Für AU empfohlen. Höhenverstellbar und neigbar und komplett mit Sondeöffnung für C.O.

 Boquerel en acero inox montada sobre carrito, con toma C.O. y doble asta de regulacion

Model	for hose Ø mm
BC-AUIII-100	100
BC-AUIII-125	125
BC-AUIII	150

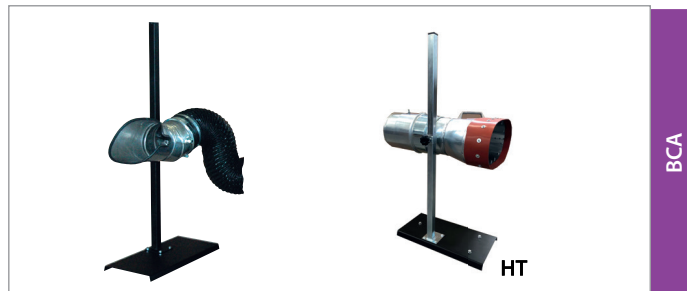



BCA

 Bocchetta in inox con scasso per ingresso sonda e asta di regolazione. Disponibile anche in versione Alta Temperatura.

 Stainless steel nozzle with inlet for C.O. tester and adjusting rod Available with high Temperatur version.

 Entonnoir en acier inox avec ouverture pour C.O monté sur pied. Disponible en version Haute Température.

 Edelstahltrichter mit Sonde Eröffnung und Stativ. Verfügbar auch mit Hohe Temperatur Version.

 Boquerel en acero inox con toma C.O. y asta de regulation de altura. Disponible con versión Alta Temperatura.

Model	for hose Ø mm
BCA-250	100
BCA-500	150

Model	for hose Ø mm
BCA-B0-T-HT-200-MGN	200



BRMS

 Bocchetta carrellata con 2 coni in gomma BGT montati su aste regolabili verticalmente e orizzontalmente.

 Trolley mounted nozzle with scratch proof rubber cones BGT with rods for vertical and horizontal adjustment

 Double entonnoir en caoutchouc BGT sur chariot avec regulation horizontale et verticale.

 2 Gummitrichter Modell BGT montiert auf einem Wagen mit Stativ, vertikal und horizontal verstellbar.

 Doble boquerel de goma BGT dobles tubo de escape, con astas de regulación vertical y horizontal. Montado sobre carro con 4 ruedas giratorias y frenos.

Model	for hose Ø mm	suction inlet Ø mm
BRMS-75	75	140
BRMS-75/200	75	200
BRMS-100	100	140
BRMS-125	125	140



BRMS-SPE

 Doppia bocchetta in gomma su struttura carrellata, regolabile in altezza e inclinazione. Idonea per autovetture con doppio scarico.

 Double rubber nozzle on trolley, adjustable in height and inclination. Suitable for cars with double exhaust pipes

 Double entonnoir en caoutchouc à roulettes installé sur étrier réglable en hauteur. Adapté pour voitures.

 Wagenmontierter höhenverstellbarer doppelter Gummitrichter für PKW.





 Doble boquerel en goma sobre asta adaptable montada sobre carro. Para turismos.

Model	for hose Ø mm	suction inlet Ø mm
BRMS-SPE	100	200
BRMS-SPE-BGL-100/200	100	200
BRMS-SPE-BG100/140	100	140
BRMS-SPE-FIRE 4	100	200

Y100 / Y75







Y100 / Y75

-  Adattatore ad Y per veicoli con doppio scarico.
-  Adaptor with double nozzle for twin pipes' vehicle .
-  Double entonnoir en caoutchouc pour vehicules avec double échappement.
-  Trichter für doppel Auspuff .
-  Doble boquerel en goma para vehiculos con doble escape.

Model	for hose Ø mm	suction inlet Ø mm
Y75-BGT-75/140	75	140
Y100-BGT-75/140	75	140
Y100-BGT-100/140	100	140
Y100-BG-100/200	100	200
Y125-BG-100/200	125	200







Y100 / Y75

-  Adattatore ad Y per veicoli con doppio scarico.
-  Adaptor with double nozzle for twin pipes' vehicle.
-  Double entonnoir en caoutchouc pour vehicules avec double échappement.
-  Trichter für doppel Auspuff.
-  Doble boquerel en goma para vehiculos con doble escape.

Model	for hose Ø mm	suction inlet Ø mm
Y75-BG-75/140-PM	75	140
Y100-BG-75/140-PM	75	140
Y100-BG-100/140-PM	100	140
Y100-BG-100/200-PM	100	200







Y100 / Y75

-  Adattatore ad Y per veicoli con doppio scarico.
-  Adaptor with double nozzle for twin pipes' vehicle.
-  Double entonnoir en caoutchouc pour vehicules avec double échappement.
-  Trichter für doppel Auspuff.
-  Doble boquerel en goma para vehiculos con doble escape.

Model	for hose Ø mm	suction inlet Ø mm
Y75-BGA-75	75	165x88
Y100-BGA-75	100	165x88
Y100-BGA-100	100	165x88







Y100 / Y75

-  Adattatore ad Y per veicoli con doppio scarico accoppiato.
-  Adaptor with double nozzle for twin pipes' vehicle .
-  Double entonnoir en caoutchouc pour vehicules avec double échappement.
-  Trichter für doppel Auspuff .
-  Doble boquerel en goma para vehiculos con doble escape.

Model	for hose Ø mm	suction inlet Ø mm
Y75-BGA-75-PM	75	165x88
Y100-BGA-75-PM	100	165x88
Y100-BGA-100-PM	100	165x88





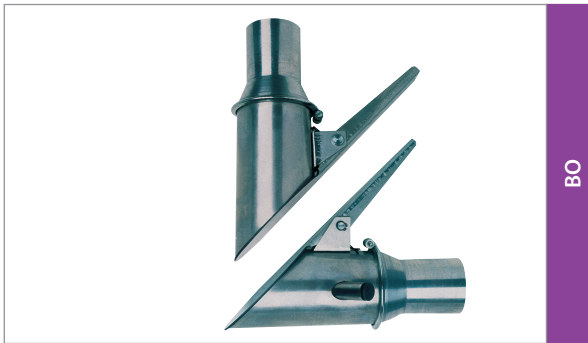

Y100 / Y75

-  Adattatore ad Y per veicoli con doppio scarico accoppiato.
-  Adaptor with double nozzle for twin pipes' vehicle .
-  Double entonnoir en caoutchouc pour vehicules avec double échappement.
-  Trichter für doppel Auspuff .
-  Doble boquerel en goma para vehiculos con doble escape.

Model	for hose Ø mm	suction inlet Ø mm
Y75-BG-75/200-PI	75	200
Y100-BG-100/200-PI	100	200



BO





-  Bocchetta in acciaio inox con paletta di chiusura e, a richiesta, apertura per sonda C.O.
-  Stainless steel nozzle with closing flap and intake for C.O. (Ø 20 mm) tester on request.
-  Entonnoir en acier inox avec clapet de fermeture et, sur demande, prise C.O. (Ø 20 mm)
-  Edelstahltrichter mit Klappe und (auf Anfrag) C.O Anschluss für die Sonde (20 mm)
-  Boquerel de acero inoxidable con tapa de cierre, y, bajo pedido, con toma de CO. (Ø 20 mm).

Model	for hose Ø mm	suction inlet Ø mm
BOC-75/100	75	100
BO-75/100 *	75	100
BO-100/100 *	100	100
BO-100/140 *	100	140
BO-100/160 *	100	160
BO-125/140 *	125	140
BO-125/180 *	125	180
BO-150/180 *	150	180
BO-180/180 *	180	180

(*) C.O. on request
C.O. su richiesta
C.O. sur demande
C.O. auf Wunsch
C.O. bajo demanda



BR



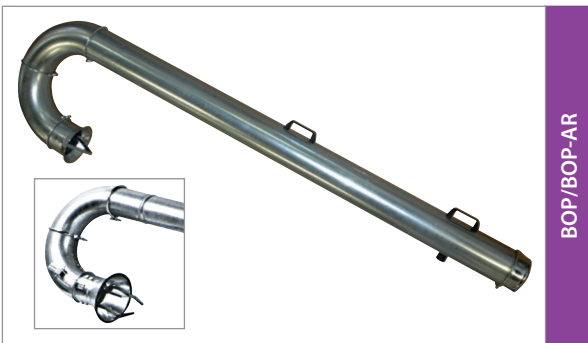

-  Bocchetta rettangolare in acciaio inox con paletta di chiusura e, a richiesta, apertura per sonda C.O.
-  Stainless steel rectangular nozzle with closing flap and intake for C.O. (Ø 20 mm) tester on request.
-  Entonnoir rectangulaire en acier inox avec clapet de fermeture et, sur de-mande, prise C.O. (Ø 20 mm)
-  Rechteckiger Edelstahltrichter mit Klappe und (Auf Anfrage) C.O. Sondeanschluss (DN 20 mm)
-  Boquerel rectangular de acero inoxidable con tapa de cierre, y, bajo pedido, con toma de CO. (Ø 20 mm)

Model	for hose Ø mm	suction inlet Ø mm
BR-75/160 *	75	160x90
BR-75/200 *	75	200x110
BR-100/200 *	100	200x110
BR-125/200 *	125	200x110

(*) C.O. on request
C.O. su richiesta
C.O. sur demande
C.O. auf Wunsch
C.O. bajo demanda



BOP/BOP-AR

-  Bocchetta in metallo per scarichi verticali disponibile con e senza dispositivo con pinza autocentrante di posizionamento
-  Metal nozzle for vertical stacks with or without self centering device for positioning.
-  Entonnoir en tôle d'acier pour échappement vertical avec ou sans dispositif de positionnement ajustable.
-  Metall Trichter für vertical Auspuffe mit oder ohne Zentriervorrichtungzange
-  Boquerel de acero para tubos de escape verticales. Con, y sin pinza autocentrante, para un correcto posicionamiento

Model	for hose Ø mm	suction inlet Ø mm
BOP-100	100	165
BOP-125	125	165
BOP-150	150	165
BOP-100-AR	100	165
BOP-125-AR	125	165

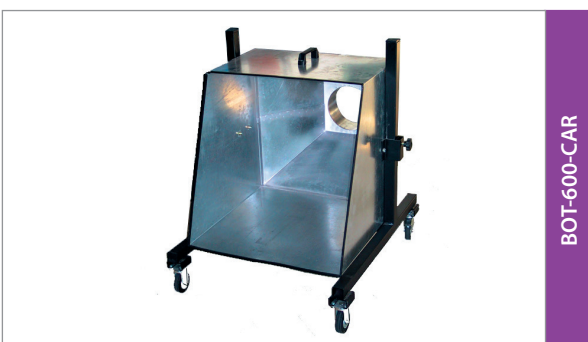

BOT-600-CAR

-  Bocchetta carrellata in metallo prova potenza di veicoli industriali
-  Trolley mounted metal nozzle for truck's power tests
-  Entonnoir en tôle d'acier sur chariot pour essay de puissance de PL
-  Wagenmontiert metall Trichter für Leistungsprüfstand für LWK
-  Boquerel de acero sobre carrito para prueba de potencia de camiones y vehículos pesados

Model	for hose Ø mm	suction inlet Ø mm
BOT-600-CAR	200	600x600