

UNITÀ FILTRANTI MOBILI



TROLLEY MOUNTED FILTERING UNITS
UNITÉS MOBILES DE FILTRAGE
MOBILE-FILTEREINHEITEN
MAQUINAS FILTRANTES SOBRE RUEDAS



Unità portatile per l'aspirazione e la filtrazione di fumi di saldatura leggera o a stagno. Dotato di cartuccia filtrante, carboni attivi e cavo di collegamento, MINI90-NG è la soluzione pronta all'uso per lavori a banco e di precisione.



Portable unit for filtering and extracting light or tin welding fumes. Equipped with cartridge filter activated carbon cell, connections wire, MINI90-NG is the right solution ready to be used for bench and precision work.



Unité portable pour l'aspiration et la filtration des fumées de soudure légère ou à étain. Equipé de cartouche filtrante, charbon actif et câble de connexion, MINI90-NG est la solution prête pour le travail au banc et de précision.



Mobile Maschine fuer die Absaugung und Filterung von lichten Schweißrauch oder Hartlöten. Ausgestattet mit Filterkartuschen, Aktivhole und Kabelanschluss, MINI90-NG ist die fertig Lösung für Werkbank und Präzisionsarbeit.



Maquinas filtrantes sobre ruedas para la aspiracion y filtracion de humos de soldadura lijera o de estaño. MINI90-NG lleva cartuchos filtrantes de carbonos activos y cable de connexion electrico y se presenta como una rapida solucion para trabajos de precision y de mesa.



Light

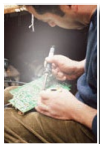

MINI90-NG

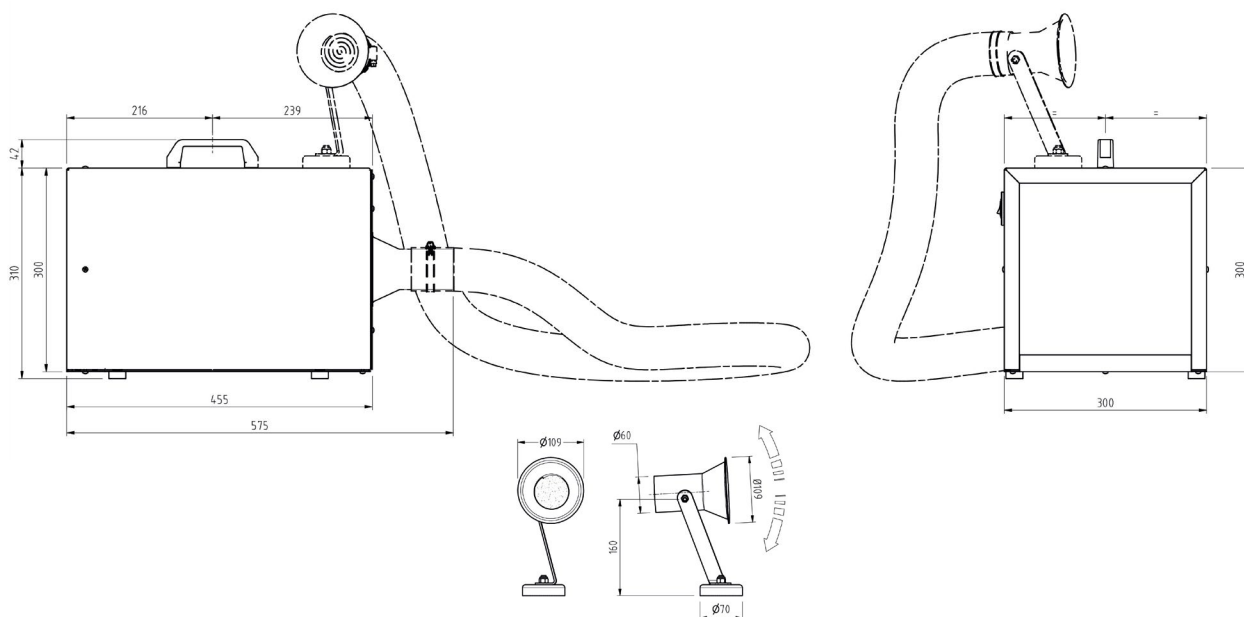

Ricambi - Spare parts - Pièces de rechange - Ersatzteile - Recambios

MINI90-NG/CAP

Supporto magnetico, staffa, cappetta e filtro antiscintilla -
Magnetic support, bracket, cap and spark filter -
Support magnetique, support, capuchon et filtre à étin-
celles -
Magnet Halterung, Halterung, Kappe und Funkenfilter -
Soporte Magnético, soporte, tapa y filtro de chispa.



MINI90-NG/SPARK

Filtro antiscintilla - Spark filter - Filtre à étin-
celles - Funkenfilter - Filtro de chispas

MINI90-NG/TUBO

Ø 60 mm - L. 3 mt



MINI90-NG/CARB

2 Kg Carboni att.
2 Kg Active Carb.
2 Kg Carbon Act.
2 Kg Aktivkohle
2 Kg Carbon Act.



MINI90-NG/CART





Dettagli tecnici - Technical details - Données techniques - Technische Daten - Datos Técnicos

Model	W	m³/h	c.f.m.	mm H ₂ O	Pa	%	Kg	Lbs	Carb. Kg	Carb. Lbs	m²	dB	V/Hz	L. flex
MINI90-NG	1100	163	96	660	6600	99	18	40	2	4,4	1,12	73	230/50	3 mt



 Il FILGO è un'unità di filtraggio mobile e compatta, progettata per un uso occasionale e senza grandi concentrazioni di inquinanti, fumi o polveri. È dotato di un braccio flessibile ARMFLEX di 3 metri, molto facile da usare e molto flessibile. Questa unità di filtrazione mobile è per 1 postazione di lavoro. È destinata principalmente alla saldatura a stagno, all'elettrodo ossiacetilenico, al MIG/MAG, al TIG, alla smerigliatura e ai gas e vapori tossici. Il braccio ARMFLEX è facile da maneggiare e molto leggero. La presa elettrica è già montata sull'unità, il sistema di filtrazione a cartuccia e il contatore integrato. L'efficienza di filtrazione è elevata grazie alla 12 m² di superficie filtrante della cartuccia. La gestione del filtro avviene tramite un contatore che consente di lavorare sempre in modo sicuro.

 The FILGO is a mobile, compact filter unit, designed for occasional use and without great concentration of pollutants, smoke or dust. It is equipped with a 3 mt ARMFLEX arm which is very easy to use and very flexible as well. This mobile filtration unit is for 1 workstation. It is intended primarily for tin welding, oxyacetylene electrode, MIG/MAG, TIG, grinding and toxic gas, vapors. The ARMFLEX arm is easy to handle and very light. The electrical socket is already mounted on the unit, there is cartridge filtration system and integrated hour counter. ped with a 3 mt ARMFLEX flexible arm which is very easy to use and very flexible as well. There is high filtration efficiency thanks to the 12 m² filtering surface of the cartridge. Filter management is done by using an hour counter that allows you to work always in a safe way.

 Le FILGO est un filtre mobile, compact, conçu pour une utilisation ponctuelle et sans grande concentration de polluants, fumées ou poussières. Il est équipé d'un bras flexible ARMFLEX de 3 m qui est d'une très grande facilité d'utilisation et d'une souplesse sans égal. Le bras ARMFLEX est maniable et très léger. La prise électrique est déjà montée sur le groupe. Système de filtration à cartouche. Compteur horaire intégré. Ce système d'aspiration mobile est pour 1 poste de travail. Il est destiné principalement à une utilisation type soudure à l'étain, oxyacétylénique à électrode, MIG/MAG, TIG, meulage et gaz toxique, vapeurs, brouillards en suspension. Grande efficacité de filtration grâce à la cartouche de 12 m² de surface filtrante. La gestion du filtre à l'aide d'un compteur horaire permet de toujours travailler en sécurité.

 FILGO ist ein mobiles und kompaktes Filtergerät, konzipiert für den gelegentlichen Einsatz und ohne große Konzentrationen an Schadstoffen, Dämpfen oder Staub. Es ist komplett mit Flexarm Modell ARMTL 3 m. Lang. Das mobile Gerät ist für einen Arbeitsplatz gedacht. Es ist hauptsächlich für Rauch von Lötens, MIG/MAG und TIG schweißen und schleifen und giftigen Gasen und Dämpfen. Der ARMFLEX Arm ist einfach zu handhaben und sehr leicht. Die Steckdose, Patronenfilter und Stundenzähler sind bereits in der Maschine eingebaut und enthalten. Die Filtereffizienz ist hoch, dank der 12 m² Patronenfilterfläche. Die Filterverwaltung erfolgt über einen Betriebsstundenzähler, so dass Sie immer sicher arbeiten können.

 El FILGO es una unidad de filtración compacta y móvil diseñada para un uso ocasional sin grandes concentraciones de contaminantes, humos o polvo. Está equipada con un brazo flexible ARMFLEX de 3 metros, muy fácil de utilizar y muy flexible. Esta unidad de filtración móvil es para 1 puesto de trabajo. Está destinada principalmente a la soldadura con estaño, electrodo oxiacetilénico, MIG/MAG, TIG, esmerilado y gases y vapores tóxicos. El brazo ARMFLEX es fácil de manejar y muy ligero. La toma eléctrica ya está montada en la unidad, el sistema de filtración de cartucho y el contador de horas están integrados. La eficacia de filtración es elevada gracias a la superficie filtrante de 12 m² del cartucho. El filtro se gestiona mediante un contador de horas, que permite un funcionamiento seguro en todo momento.



Light

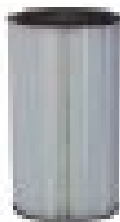

FILGO/CART

: CELLULOSE - 12m² - >99,9% - M-CEL

OPTIONAL



BRACCIO ARTICOLATO AUTOPORTANTE L.3,0 mt Ø150mm
Cappetta standard in plastica

SELF SUPPORTING ARTICULATED ARM L.3,0 mt Ø150mm
Standard plastic cap

BRAS ARTICULÉ AUTOPORTEUR L.3,0 mt Ø150mm
Bouchon en plastique standard

SELBSTSTÄNDIGER GELENKARM L.3,0 mt Ø150mm
Standard-Kunststoffkappe

BRAZO ARTICULADO AUTOPORTANTE L.3,0 mt Ø150mm
Tapa de plástico estándar

Dettagli tecnici - Technical details - Données techniques - Technische Daten - Datos Técnicos

Model		%	m ²		Carb. Kg	Carb. Lbs		cert	
FILGO-NG	1400 m ³ /h 823 c.f.m.	95	12	80 kg* 177 lb	-	-	400 V - 50 Hz - 3ph (3p+T)	CE	1,5 Hp 1,1kW

* Peso senza braccio - Poids sans bras - Weight w/o arm - Gewicht ohne Arm - Peso sin brazo



Sistema di articolazione montato all'interno, Ø 160 mm (portata di 1.400 m³/h mantenuta).

Internally mounted articulation system, Ø 160 mm (flow rate of 1,400 m³/h maintained).

Système d'articulation monté à l'intérieur, Ø 160 mm (débit maintenu à 1 400 m³/h).

Innenliegendes Gelenksystem, Ø 160 mm (Durchflussmenge von 1.400 m³/h wird beibehalten).

Sistema de articulación montado internamente, Ø 160 mm (caudal mantenido de 1.400 m³/h).







 Unità carrellata da 1,5 HP per l'aspirazione e la filtrazione di fumi di saldatura in impieghi poco gravosi. Agile, maneggevole e performante, ECOMINOR è equipaggiato con una batteria di 4 filtri in sequenza per filtrare meccanicamente e deodorare il fumo aspirato. Braccio autoportante articolato da 3 mt incluso. Portata max di 1.400 m³/h. Idoneo per impieghi poco gravosi.

 A 1.5 HP, trolley mounted unit for extracting and filtering fumes produced in light welding applications. ECOMINOR is agile, manageable and offers high performance, it is supplied with a battery of 4 mechanical filters in sequence that filter and deodorise the fumes. A 3 m self-supporting articulated arm is included. Max capacity 1.400 m³/h. Light process.

 Unité mobile de 1,5 HP pour l'aspiration et la filtration de fumées de soudure lors d'utilisations légères. Agile, maniable et puissant, ECOMINOR est équipé d'une batterie de 4 filtres successifs pour le filtrage mécanique et la désodorisation de la fumée aspirée. Equipé avec bras articulé autoportant de 3 m. Débit max de 1.400 m³/h. Emplois peu lourdes.

 Fahrbare 1,5 PS Einheit für das Absaugen und Filtern von Schweißrauch für den leichteren Einsatz. ECOMINOR ist handlich, beweglich und leistungsstark und mit einer Batterie von 4 Reihenfiltern für die mechanische Filterung und Geruchsverbesserung des angesaugten Rauchs ausgestattet. Geliefert mit einen selbsttragenden Gelenkarm 3 m Lang. Max. Förderleistung 1.400 m³/h. Wenig schweren Arbeiten.

 Unidad móvil de 1,5 HP para aspirar y filtrar humos de soldadura en condiciones de empleo ligero. Ágil, manejable y funcional, ECOMINOR está equipada con una batería de 4 filtros en secuencia para filtrar mecánicamente y desodorizar el humo aspirado. Equipado con brazo articulado de 3 m. Caudal máx. 1.400 m³/h. Empleos ligeros.

OPTIONAL

ARMFLEX420/C

BRACCIO ARTICOLATO AUTOPORTANTE L.4,0 mt Ø160mm

Cappetta standard in plastica

SELF SUPPORTING ARTICULATED ARM L.4,0 mt Ø160mm

Standard plastic cap

BRAS ARTICULÉ AUTOPORTEUR L.4,0 mt Ø160mm

Bouchon en plastique standard

SELBSTSTÄNDIGER GELENKARM L.4,0 mt Ø160mm

Standard-Kunststoffkappe

BRAZO ARTICULADO AUTOPORTANTE L.4,0 mt Ø160mm

Tapa de plástico estandare



Light

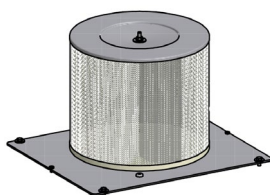
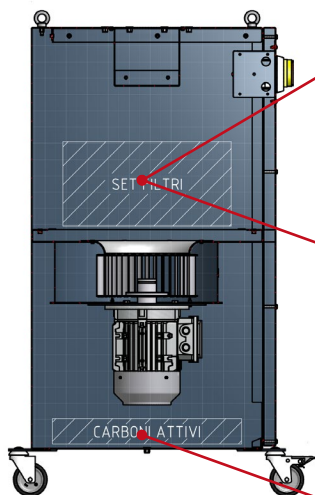

ECOMINOR-NG/CART : CELLULOSE Ø350 - H300 - EN 60335-2-69 - Class M

ECOMINOR-NG/CART-P : POLYESTER Ø350 - H300 - EN 60335-2-69 - Class M

ECOMINOR-NG/CART-HEPA : POLYESTER HEPA Ø350 - H300 - EN 1822 - Class H13

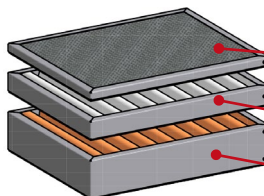

ECOMINOR-NG/RIPM : PREFILTRO METALLICO / METAL PREFILTER

ECOMINOR-NG/RIPS : PREFILTRO SINTETICO / PREFILTER

ECOMINOR-NG/RIF : FILTRO ALTA EFFICIENZA / HIGH EFFICIENCY FILTER

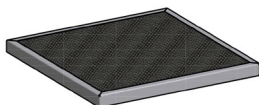

ECOMINOR-NG/CONT4.5 : FILTRO A CARBONI ATTIVI / CARBON FILTER 4,5 Kg

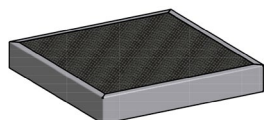

ECOMINOR-NG/CONT10 : FILTRO A CARBONI ATTIVI / CARBON FILTER 10 Kg

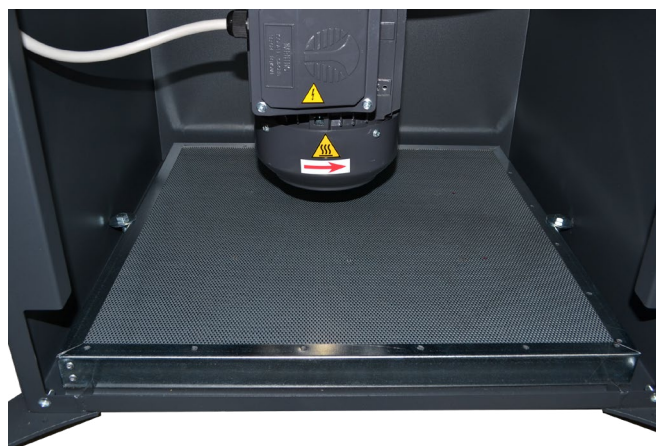



Dettagli tecnici - Technical details - Données techniques - Technische Daten - Datos Técnicos

Model		%	m ²		Carb. Kg	Carb. Lbs		cert	
ECOMINOR-NG-FLEX	1400 m ³ /h 823 c.f.m.	95	1,2	94 kg 207 lb	4,5	9,9	400 V - 52 Hz - 3ph (3p+T)	CE	1,5 Hp 1,1kW
ECOMINOR-NG-FLEX-CARB	1400 m ³ /h 823 c.f.m.	90	0,3	99 kg 218 lb	10	22	400 V - 52 Hz - 3ph (3p+T)	CE	1,5 Hp 1,1kW
ECOMINOR-NG-FLEX-C	1600 m ³ /h 882 c.f.m.	99,95	6	94 kg 207 lb	-	-	400 V - 52 Hz - 3ph (3p+T)	CE	1,5 Hp 1,1kW
ECOMINOR-NG-FLEX-C-4.5CA	1600 m ³ /h 882 c.f.m.	99,95	6	99 kg 218 lb	4,5	9,9	400 V - 52 Hz - 3ph (3p+T)	CE	1,5 Hp 1,1kW
ECOMINOR-NG-FLEX-C-10CA	1600 m ³ /h 882 c.f.m.	99,95	6	104 kg 229 lb	10	22	400 V - 52 Hz - 3ph (3p+T)	CE	1,5 Hp 1,1kW
ECOMINOR-NG-FLEX-C/P	1600 m ³ /h 882 c.f.m.	99,95	6	94 kg 207 lb	-	-	400 V - 52 Hz - 3ph (3p+T)	CE	1,5 Hp 1,1kW
ECOMINOR-NG-FLEX-C/P-4.5CA	1600 m ³ /h 882 c.f.m.	99,95	6	99 kg 218 lb	4,5	9,9	400 V - 52 Hz - 3ph (3p+T)	CE	1,5 Hp 1,1kW
ECOMINOR-NG-FLEX-C/P-10CA	1600 m ³ /h 882 c.f.m.	99,95	6	104 kg 229 lb	10	22	400 V - 52 Hz - 3ph (3p+T)	CE	1,5 Hp 1,1kW
ECOMINOR-NG-FLEX-HEPA	1400 m ³ /h 823 c.f.m	99,95	6	94 kg 207 lb	-	-	400 V - 52 Hz - 3ph (3p+T)	CE	1,5 Hp 1,1kW
ECOMINOR-NG-FLEX-HEPA-4.5CA	1400 m ³ /h 823 c.f.m	99,95	6	99 kg 218 lb	4,5	9,9	400 V - 52 Hz - 3ph (3p+T)	CE	1,5 Hp 1,1kW
ECOMINOR-NG-FLEX-HEPA-10CA	1400 m ³ /h 823 c.f.m	99,95	6	104 kg 229 lb	10	22	400 V - 52 Hz - 3ph (3p+T)	CE	1,5 Hp 1,1kW



 Unità carrellata da 1,5 HP per l'aspirazione e la filtrazione di fumi di saldatura in impieghi poco gravosi. Agile, maneggevole e performante, ECOMINOR è equipaggiato con una batteria di 4 filtri in sequenza per filtrare meccanicamente e deodorare il fumo aspirato. Braccio autoportante articolato da 3 mt incluso. Portata max di 1.400 m³/h. Idoneo per impieghi poco gravosi.

 A 1.5 HP, trolley mounted unit for extracting and filtering fumes produced in light welding applications. ECOMINOR is agile, manageable and offers high performance, it is supplied with a battery of 4 mechanical filters in sequence that filter and deodorise the fumes. A 3 m self-supporting articulated arm is included. Max capacity 1.400 m³/h. Light process.





 Unité mobile de 1,5 HP pour l'aspiration et la filtration de fumées de soudure lors d'utilisations légères. Agile, maniable et puissant, ECOMINOR est équipé d'une batterie de 4 filtres successifs pour le filtrage mécanique et la désodorisation de la fumée aspirée. Equipé avec bras articulé autoportant de 3 m. Débit max de 1.400 m³/h. Emplois peu lourdes.

 Fahrbare 1,5 PS Einheit für das Absaugen und Filtern von Schweißrauch für den leichteren Einsatz. ECOMINOR ist handlich, beweglich und leistungsstark und mit einer Batterie von 4 Reihenfiltern für die mechanische Filterung und Geruchsverbesserung des angesaugten Rauchs ausgestattet. Geliefert mit einen selbsttragenden Gelenkarm 3 m Lang. Max. Förderleistung 1.400 m³/h. Wenig schweren Arbeiten.

 Unidad móvil de 1,5 HP para aspirar y filtrar humos de soldadura en condiciones de empleo ligero. Ágil, manejable y funcional, ECOMINOR está equipada con una batería de 4 filtros en secuencia para filtrar mecánicamente y desodorizar el humo aspirado. Equipado con brazo articulado de 3 m. Caudal máx. 1.400 m³/h. Empleos ligeros.



Dettagli tecnici - Technical details - Données techniques - Technische Daten - Datos Técnicos

Model		%	m ²		Carb. Kg	Carb. Lbs		cert	
ECOMINOR-NG	1400 m ³ /h 823 c.f.m.	95	1,2	94 kg 207 lb	4,5	9,9	400 V - 50 Hz - 3ph (3p+T)	CE	1,5 Hp 1,1kW
ECOMINOR-NG-CARB	1400 m ³ /h 823 c.f.m.	90		99 kg 218 lb	10	22	400 V - 50 Hz - 3ph (3p+T)	CE	1,5 Hp 1,1kW
ECOMINOR-NG-C	1600 m ³ /h 882 c.f.m.	99,9	6	94 kg 207 lb	-	-	400 V - 50 Hz - 3ph (3p+T)	CE	1,5 Hp 1,1kW
ECOMINOR-NG-C-4.5CA	1600 m ³ /h 882 c.f.m.	99,9	6	99 kg 218 lb	4,5	9,9	400 V - 50 Hz - 3ph (3p+T)	CE	1,5 Hp 1,1kW
ECOMINOR-N-C-10CA	1600 m ³ /h 882 c.f.m.	99,9	6	104 kg 229 lb	10	22	400 V - 50 Hz - 3ph (3p+T)	CE	1,5 Hp 1,1kW
ECOMINOR-NG-C/P	1600 m ³ /h 882 c.f.m.	99,9	6	94 kg 207 lb	-	-	400 V - 50 Hz - 3ph (3p+T)	CE	1,5 Hp 1,1kW
ECOMINOR-NG-C/P-4.5CA	1600 m ³ /h 882 c.f.m.	99,9	6	99 kg 218 lb	4,5	9,9	400 V - 50 Hz - 3ph (3p+T)	CE	1,5 Hp 1,1kW
ECOMINOR-NG-C/P-10CA	1600 m ³ /h 882 c.f.m.	99,9	6	104 kg 229 lb	10	22	400 V - 50 Hz - 3ph (3p+T)	CE	1,5 Hp 1,1kW
ECOMINOR-NG-HEPA	1400 m ³ /h 823 c.f.m.	99,95	6	94 kg 207 lb	-	-	400 V - 50 Hz - 3ph (3p+T)	CE	1,5 Hp 1,1kW
ECOMINOR-NG-HEPA-4.5CA	1400 m ³ /h 823 c.f.m.	99,95	6	99 kg 218 lb	4,5	9,9	400 V - 50 Hz - 3ph (3p+T)	CE	1,5 Hp 1,1kW
ECOMINOR-NG-HEPA-10CA	1400 m ³ /h 823 c.f.m.	99,95	6	104 kg 229 lb	10	22	400 V - 50 Hz - 3ph (3p+T)	CE	1,5 Hp 1,1kW

ECOMINOR -NG

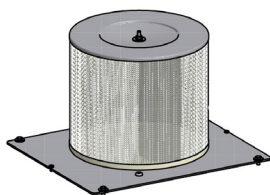
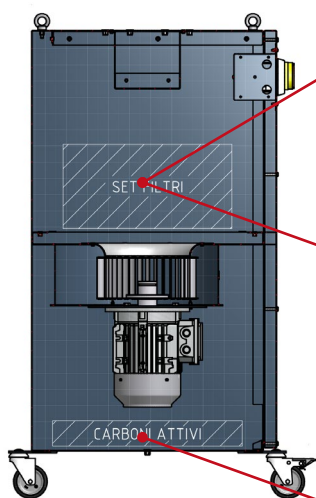
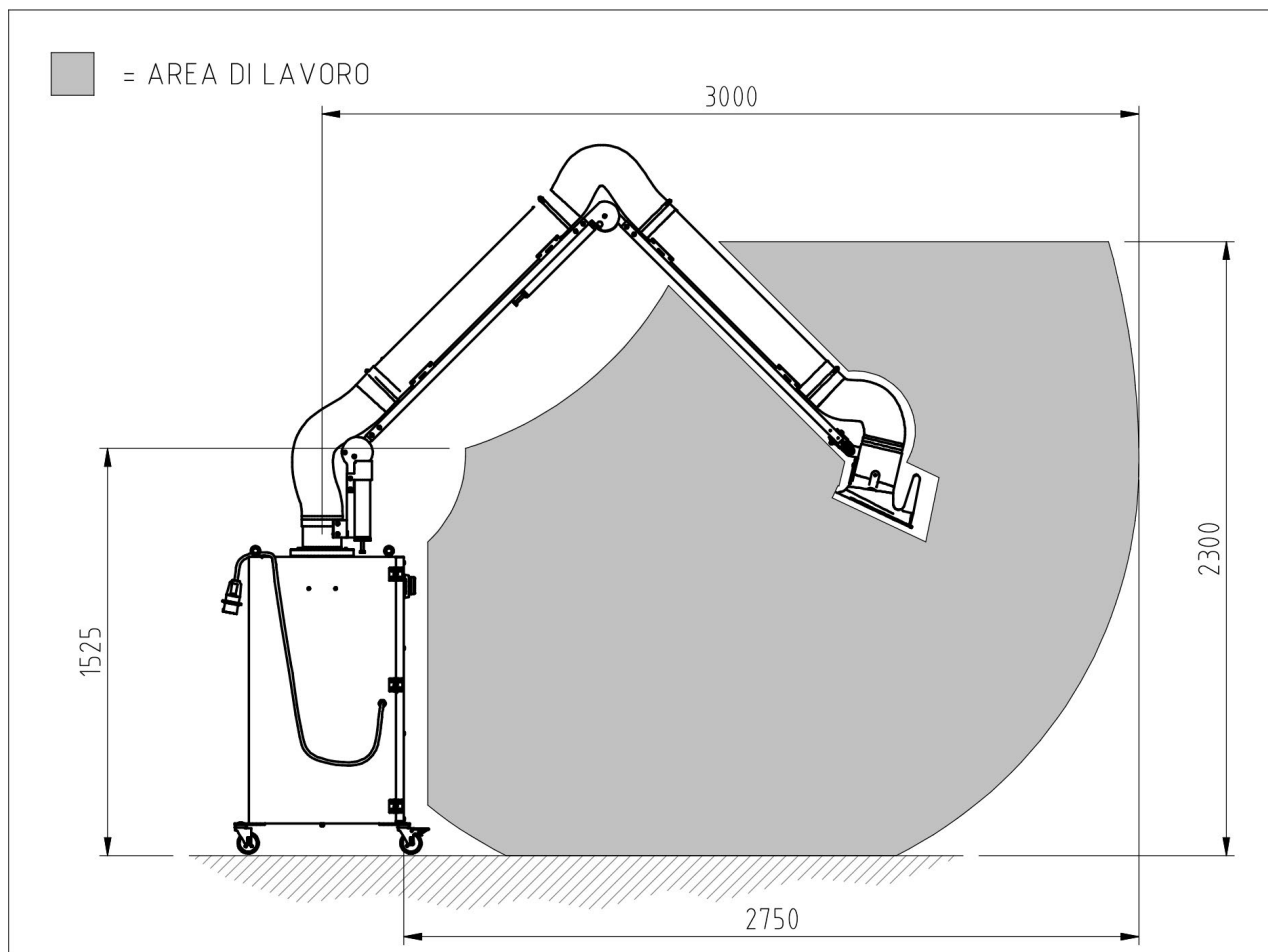

ECOMINOR-NG/CART : CELLULOSE Ø350 - H300 - EN 60335-2-69 - Class M

ECOMINOR-NG/CART-P : POLYESTER Ø350 - H300 - EN 60335-2-69 - Class M

ECOMINOR-NG/CART-HEPA : POLYESTER HEPA Ø350 - H300 - EN 1822 - Class H13

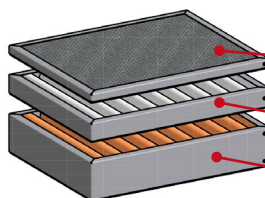

ECOMINOR-NG/RIPM : PREFILTRO METALLICO / METAL PREFILTER

ECOMINOR-NG/RIPS : PREFILTRO SINTETICO / PREFILTER

ECOMINOR-NG/RIF : FILTRO ALTA EFFICIENZA / HIGH EFFICIENCY FILTER

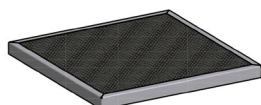

ECOMINOR-NG/CONT4.5 : FILTRO A CARBONI ATTIVI / CARBON FILTER 4,5 Kg

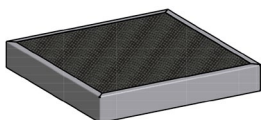

ECOMINOR-NG/CONT10 : FILTRO A CARBONI ATTIVI / CARBON FILTER 10 Kg

Tabella filtri - Filter table - Tableau des filtres - Tabelle filtern - Tabla de filtros

MODELLO	BRACCIO	FILTRI						CARBONI ATTIVI	
		FILTRI A PANNELLO			CARTUCCE			ECOMINOR- NG/CONT4.5	ECOMINOR- NG/CON10
		ECOMINOR- NG/RIPM	ECOMINOR- NG/RIPS	ECOMINOR- NG/RIF	ECOMINOR- NG/CART	ECOMINOR- NG/CART-P	ECOMINOR- NG/CART-HEPA		
ECOMINOR-NG	TECHNO3/C	✓	✓	✓	✗	✗	✗	✓	✗
ECOMINOR-NG-CARB	TECHNO3/C	✓	✓ (x2)	✗	✗	✗	✗	✗	✓
ECOMINOR-NG-C	TECHNO3/C	✗	✗	✗	✓	✗	✗	✗	✗
ECOMINOR-NG-C-4.5CA	TECHNO3/C	✗	✗	✗	✓	✗	✗	✓	✗
ECOMINOR-NG-C-10CA	TECHNO3/C	✗	✗	✗	✓	✗	✗	✗	✓
ECOMINOR-NG-C/P	TECHNO3/C	✗	✗	✗	✗	✓	✗	✗	✗
ECOMINOR-NG-C/P-4.5CA	TECHNO3/C	✗	✗	✗	✗	✓	✗	✓	✗
ECOMINOR-NG-C/P-10CA	TECHNO3/C	✗	✗	✗	✗	✓	✗	✗	✓
ECOMINOR-NG-HEPA	TECHNO3/C	✗	✗	✗	✗	✗	✓	✗	✗
ECOMINOR-NG-HEPA-4.5CA	TECHNO3/C	✗	✗	✗	✗	✗	✓	✓	✗
ECOMINOR-NG-HEPA-10CA	TECHNO3/C	✗	✗	✗	✗	✗	✓	✗	✓
ECOMINOR-NG-FLEX	ARMFLEX	✓	✓	✓	✗	✗	✗	✓	✗
ECOMINOR-NG-FLEX-CARB	ARMFLEX	✓	✓ (x2)	✗	✗	✗	✗	✗	✓
ECOMINOR-NG-FLEX-C	ARMFLEX	✗	✗	✗	✓	✗	✗	✗	✗
ECOMINOR-NG-FLEX-C-4.5CA	ARMFLEX	✗	✗	✗	✓	✗	✗	✓	✗
ECOMINOR-NG-FLEX-C-10CA	ARMFLEX	✗	✗	✗	✓	✗	✗	✗	✓
ECOMINOR-NG-FLEX-C/P	ARMFLEX	✗	✗	✗	✗	✓	✗	✗	✗
ECOMINOR-NG-FLEX-C/P-4.5CA	ARMFLEX	✗	✗	✗	✗	✓	✗	✓	✗
ECOMINOR-NG-FLEX-C/P-10CA	ARMFLEX	✗	✗	✗	✗	✓	✗	✗	✓
ECOMINOR-NG-FLEX-HEPA	ARMFLEX	✗	✗	✗	✗	✗	✓	✗	✗
ECOMINOR-NG-FLEX-HEPA-4.5CA	ARMFLEX	✗	✗	✗	✗	✗	✓	✓	✗
ECOMINOR-NG-FLEX-HEPA-10CA	ARMFLEX	✗	✗	✗	✗	✗	✓	✗	✓

Dimensioni - Dimensions - Dimensions - Abmessungen - Dimensiones

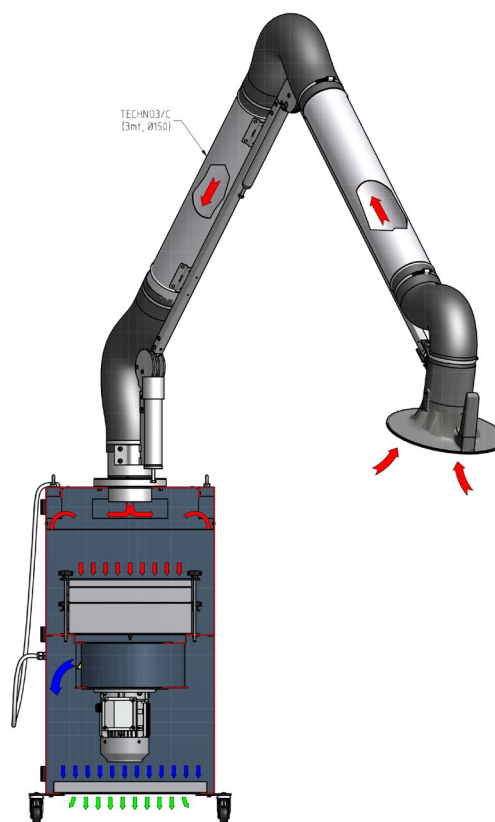
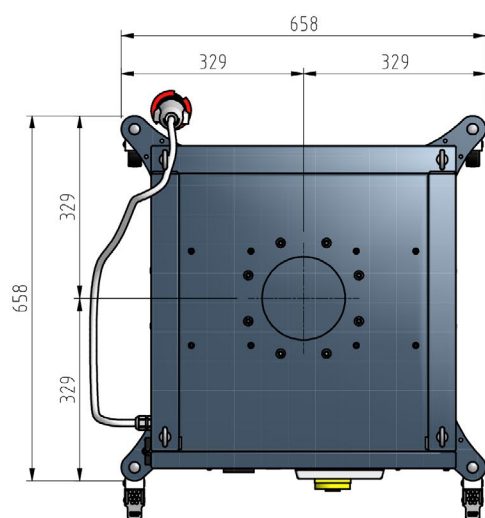
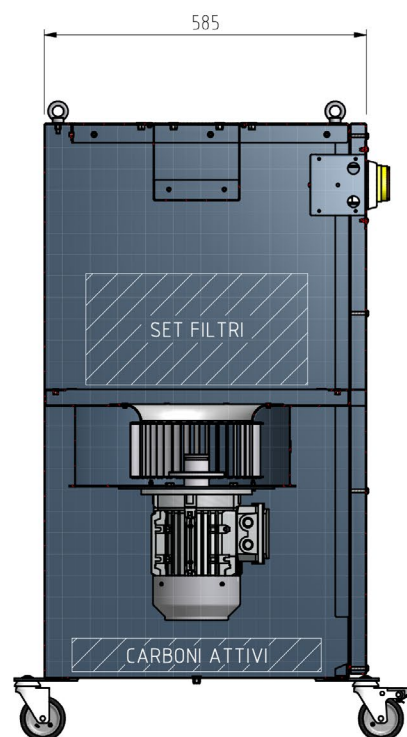
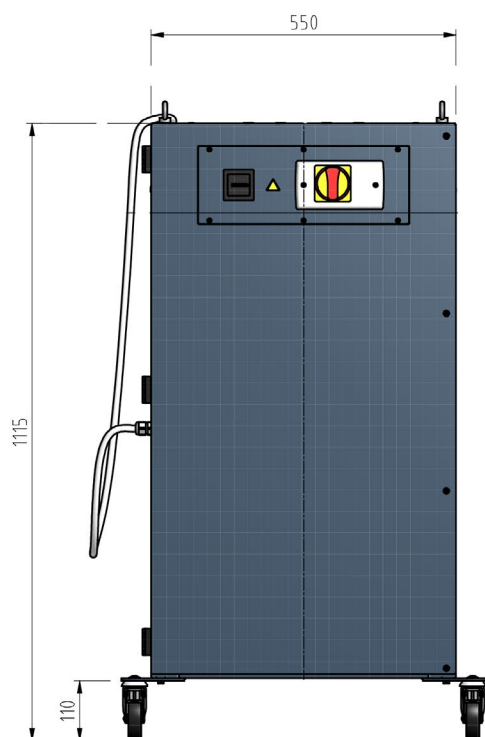



MASTER
NEXT GENERATION



Unità carrellata per l'aspirazione e la filtrazione di fumi di saldatura. Dotata di braccio articolato da 3 mt e di una batteria di filtri ad azione meccanica per filtrare e deodorare i fumi aspirati prima della reimmissione in ambiente. Disponibile nella versione con un braccio da 150 mm, 200 mm o due bracci da 150 mm.



A trolley mounted unit for extracting and filtering welding fumes. Equipped with a 3 m articulated arm and a battery of mechanical filters that filter and deodorise the fumes before they are recycled into the environment. Available with a 150 mm and a 200 mm arm, or 2 x 150 mm arms.



Unité mobile pour l'aspiration et la filtration de fumées de soudure. Équipée de bras articulé de 3 m et d'une batterie de filtres à action mécanique pour filtrer et désodoriser les fumées aspirées avant leur réémission dans l'atmosphère. Disponible en version à un bras de 150 mm, 200 mm ou deux bras de 150 mm.



Fahrbare Einheit für das Absaugen und Filtern von Schweißrauch. Ausgestattet mit 3 m Gelenkarm und einer mechanisch wirkenden Filterbatterie zur Filterung und Geruchsverbesserung der Rauche, bevor diese wieder in den Raum zurückgeführt werden. Verfügbar in der Version mit 150 mm, 200 mm Arm oder zwei 150 mm Armen.



Unidad móvil para aspirar y filtrar humos de soldadura. Equipada con brazo articulado de 3 m y batería de filtros de acción mecánica para filtrar y desodorizar los humos aspirados antes de liberarlos en el ambiente. Disponible versión con brazo de 150 mm o 200 mm, o dos brazos de 150 mm.

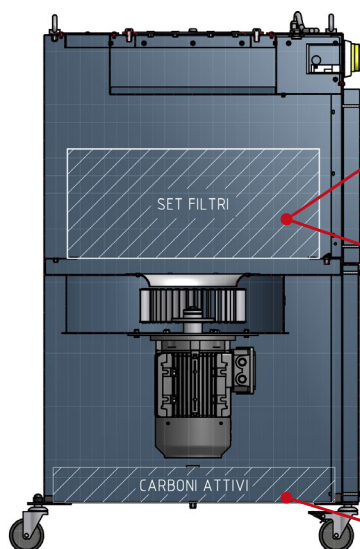

MASTER-NG/CART: 2xCELLULOSE Ø350 - H300 - EN 60335-2-69 - Class M

MASTER-NG/CART-P: 2xPOLYESTER Ø350 - H300 - EN 60335-2-69 - Class M

MASTER-NG/CAR-HEPA: 2xPOLYESTER HEPA Ø350 - H300 - EN 1822 - Class H13

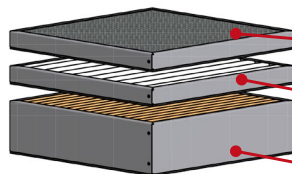

MASTER-NG/RIPM: PREFILTRO METALLICO / METAL PREFILTER

MASTER-NG/RPS: PREFILTRO SINTETICO / PREFILTER

MASTER-NG/RIF: FILTRO ALTA EFFICIENZA / HIGH EFFICIENCY FILTER

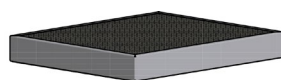

MASTER-NG/CONT: FILTRO A CARBONI ATTIVI / CARBON FILTER 16 Kg

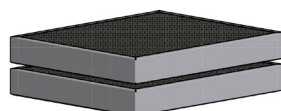

MASTER-NG/CONT X 2: FILTRO A CARBONI ATTIVI / CARBON FILTER 32 Kg

Model		%	m ²		Carb. Kg	Carb. Lbs		cert	
MASTER-NG-1BR	1.600 m ³ /h - 882 c.f.m.	95	2,75	147 kg - 324 lb	16	35,28	400 V - 50 Hz - 3ph (3p+T)	CE	3 Hp - 2,2 kW
MASTER-NG-2BR	2.500 m ³ /h - 1470 c.f.m.	95	2,75	172 kg - 380 lb	16	35,28	400 V - 50 Hz - 3ph (3p+T)	CE	3 Hp - 2,2 kW
MASTER-NG-200	2.000 m ³ /h - 1176 c.f.m.	95	2,75	148 kg - 326 lb	16	35,28	400 V - 50 Hz - 3ph (3p+T)	CE	3 Hp - 2,2 kW
MASTER-NG-1BR-CARB	1.600 m ³ /h - 882 c.f.m.	90	0,6	158 kg - 348 lb	32	70,55	400 V - 50 Hz - 3ph (3p+T)	CE	3 Hp - 2,2 kW
MASTER-NG-2BR-CARB	2.500 m ³ /h - 1470 c.f.m.	90	0,6	183 kg - 403 lb	32	70,55	400 V - 50 Hz - 3ph (3p+T)	CE	3 Hp - 2,2 kW
MASTER-NG-200-CARB	2.000 m ³ /h - 1176 c.f.m.	90	0,6	159 kg - 350 lb	32	70,55	400 V - 50 Hz - 3ph (3p+T)	CE	3 Hp - 2,2 kW
MASTER-NG-1BR-C	1.600 m ³ /h - 882 c.f.m.	99,9	18	135 kg - 297 lb	-	-	400 V - 50 Hz - 3ph (3p+T)	CE	3 Hp - 2,2 kW
MASTER-NG-2BR-C	2.500 m ³ /h - 1470 c.f.m.	99,9	18	160 kg - 352 lb	-	-	400 V - 50 Hz - 3ph (3p+T)	CE	3 Hp - 2,2 kW
MASTER-NG-200-C	2.000 m ³ /h - 1176 c.f.m.	99,9	18	136 kg - 300 lb	-	-	400 V - 50 Hz - 3ph (3p+T)	CE	3 Hp - 2,2 kW
MASTER-NG-1BR-C-16CA	1.600 m ³ /h - 882 c.f.m.	99,9	18	151 kg - 332 lb	16	35,28	400 V - 50 Hz - 3ph (3p+T)	CE	3 Hp - 2,2 kW
MASTER-NG-2BR-C-16CA	2.500 m ³ /h - 1470 c.f.m.	99,9	18	176 kg - 388 lb	16	35,28	400 V - 50 Hz - 3ph (3p+T)	CE	3 Hp - 2,2 kW
MASTER-NG-200-C-16CA	2.000 m ³ /h - 1176 c.f.m.	99,9	18	152 kg - 335 lb	16	35,28	400 V - 50 Hz - 3ph (3p+T)	CE	3 Hp - 2,2 kW
MASTER-NG-1BR-C-32CA	1.600 m ³ /h - 882 c.f.m.	99,9	18	167 kg - 368 lb	32	70,55	400 V - 50 Hz - 3ph (3p+T)	CE	3 Hp - 2,2 kW
MASTER-NG-2BR-C-32CA	2.500 m ³ /h - 1470 c.f.m.	99,9	18	192 kg - 423 lb	32	70,55	400 V - 50 Hz - 3ph (3p+T)	CE	3 Hp - 2,2 kW
MASTER-NG-200-C-32CA	2.000 m ³ /h - 1176 c.f.m.	99,9	18	168 kg - 370 lb	32	70,55	400 V - 50 Hz - 3ph (3p+T)	CE	3 Hp - 2,2 kW
MASTER-NG-1BR-32CA	1.600 m ³ /h - 882 c.f.m.	95	2,75	147 kg - 324 lb	32	70,55	400 V - 50 Hz - 3ph (3p+T)	CE	3 Hp - 2,2 kW
MASTER-NG-2BR-32CA	2.500 m ³ /h - 1470 c.f.m.	95	2,75	172 kg - 380 lb	16	70,55	400 V - 50 Hz - 3ph (3p+T)	CE	3 Hp - 2,2 kW
MASTER-NG-200-32CA	2.000 m ³ /h - 1176 c.f.m.	95	2,75	148 kg - 326 lb	16	70,55	400 V - 50 Hz - 3ph (3p+T)	CE	3 Hp - 2,2 kW
MASTER-NG-1BR-C/P	1.600 m ³ /h - 882 c.f.m.	99,9	18	135 kg - 297 lb	-	-	400 V - 50 Hz - 3ph (3p+T)	CE	3 Hp - 2,2 kW
MASTER-NG-2BR-C/P	2.500 m ³ /h - 1470 c.f.m.	99,9	18	160 kg - 352 lb	-	-	400 V - 50 Hz - 3ph (3p+T)	CE	3 Hp - 2,2 kW
MASTER-NG-200C/P	2.000 m ³ /h - 1176 c.f.m.	99,9	18	136 kg - 300 lb	-	-	400 V - 50 Hz - 3ph (3p+T)	CE	3 Hp - 2,2 kW
MASTER-NG-1BR-C/P-16CA	1.600 m ³ /h - 882 c.f.m.	99,9	18	151 kg - 332 lb	16	35,28	400 V - 50 Hz - 3ph (3p+T)	CE	3 Hp - 2,2 kW
MASTER-NG-2BR-C/P-16CA	2.500 m ³ /h - 1470 c.f.m.	99,9	18	176 kg - 388 lb	16	35,28	400 V - 50 Hz - 3ph (3p+T)	CE	3 Hp - 2,2 kW
MASTER-NG-200C/P-16CA	2.000 m ³ /h - 1176 c.f.m.	99,9	18	152 kg - 335 lb	16	35,28	400 V - 50 Hz - 3ph (3p+T)	CE	3 Hp - 2,2 kW
MASTER-NG-1BR-C/P-32CA	1.600 m ³ /h - 882 c.f.m.	99,9	18	167 kg - 368 lb	32	70,55	400 V - 50 Hz - 3ph (3p+T)	CE	3 Hp - 2,2 kW
MASTER-NG-2BR-C/P-32CA	2.500 m ³ /h - 1470 c.f.m.	99,9	18	192 kg - 423 lb	32	70,55	400 V - 50 Hz - 3ph (3p+T)	CE	3 Hp - 2,2 kW
MASTER-NG-200C/P-32CA	2.000 m ³ /h - 1176 c.f.m.	99,9	18	168 kg - 370 lb	32	70,55	400 V - 50 Hz - 3ph (3p+T)	CE	3 Hp - 2,2 kW
MASTER-NG-1BR-HEPA	1.600 m ³ /h - 882 c.f.m.	99,95	18	135 kg - 297 lb	-	-	400 V - 50 Hz - 3ph (3p+T)	CE	3 Hp - 2,2 kW
MASTER-NG-2BR-HEPA	2.500 m ³ /h - 1470 c.f.m.	99,95	18	160 kg - 352 lb	-	-	400 V - 50 Hz - 3ph (3p+T)	CE	3 Hp - 2,2 kW
MASTER-NG-200-HEPA	2.000 m ³ /h - 1176 c.f.m.	99,95	18	136 kg - 300 lb	-	-	400 V - 50 Hz - 3ph (3p+T)	CE	3 Hp - 2,2 kW
MASTER-NG-1BR-HEPA-16CA	1.600 m ³ /h - 882 c.f.m.	99,95	18	151 kg - 332 lb	16	35,28	400 V - 50 Hz - 3ph (3p+T)	CE	3 Hp - 2,2 kW
MASTER-NG-2BR-HEPA-16CA	2.500 m ³ /h - 1470 c.f.m.	99,95	18	176 kg - 388 lb	16	35,28	400 V - 50 Hz - 3ph (3p+T)	CE	3 Hp - 2,2 kW
MASTER-NG-200-HEPA-16CA	2.000 m ³ /h - 1176 c.f.m.	99,95	18	152 kg - 335 lb	16	35,28	400 V - 50 Hz - 3ph (3p+T)	CE	3 Hp - 2,2 kW
MASTER-NG-1BR-HEPA-32CA	1.600 m ³ /h - 882 c.f.m.	99,95	18	167 kg - 368 lb	32	70,55	400 V - 50 Hz - 3ph (3p+T)	CE	3 Hp - 2,2 kW
MASTER-NG-2BR-HEPA-32CA	2.500 m ³ /h - 1470 c.f.m.	99,95	18	192 kg - 423 lb	32	70,55	400 V - 50 Hz - 3ph (3p+T)	CE	3 Hp - 2,2 kW
MASTER-NG-200-HEPA-32CA	2.000 m ³ /h - 1176 c.f.m.	99,95	18	168 kg - 370 lb	32	70,55	400 V - 50 Hz - 3ph (3p+T)	CE	3 Hp - 2,2 kW

Tabella filtri - Filter table - Tableau des filtres - Tabelle filtern - Tabla de filtros

MODELLO	MASTER-NG/RIPM	MASTER-NG/RIPS	MASTER-NG/RIF	MASTER-NG/CART (x2)	MASTER-NG/CART-P (x2)	MASTER-NG/CART-HEPA (x2)	MASTER-NG/CONT	MASTER-NG/CONT (x2)
MASTER-NG-1BR	✓	✓	✓	✗	✗	✗	✓	✗
MASTER-NG-2BR	✓	✓	✓	✗	✗	✗	✓	✗
MASTER-NG-200	✓	✓	✓	✗	✗	✗	✓	✗
MASTER-NG-1BR-32CA	✓	✓	✓	✗	✗	✗	✗	✓
MASTER-NG-2BR-32CA	✓	✓	✓	✗	✗	✗	✗	✓
MASTER-NG-200-32CA	✓	✓	✓	✗	✗	✗	✗	✓
MASTER-NG-1BR-CARB	✓	✓	✗	✗	✗	✗	✗	✓
MASTER-NG-2BR-CARB	✓	✓	✗	✗	✗	✗	✗	✓
MASTER-NG-200-CARB	✓	✓	✗	✗	✗	✗	✗	✓
MASTER-NG-1BR-C	✗	✗	✗	✓	✗	✗	✗	✗
MASTER-NG-2BR-C	✗	✗	✗	✓	✗	✗	✗	✗
MASTER-NG-200-C	✗	✗	✗	✓	✗	✗	✗	✗
MASTER-NG-1BR-C-16CA	✗	✗	✗	✓	✗	✗	✓	✗
MASTER-NG-2BR-C-16CA	✗	✗	✗	✓	✗	✗	✓	✗
MASTER-NG-200-C-16CA	✗	✗	✗	✓	✗	✗	✓	✗
MASTER-NG-1BR-C-32CA	✗	✗	✗	✓	✗	✗	✗	✓
MASTER-NG-2BR-C-32CA	✗	✗	✗	✓	✗	✗	✗	✓
MASTER-NG-200-C-32CA	✗	✗	✗	✓	✗	✗	✗	✓
MASTER-NG-1BR-C/P	✗	✗	✗	✗	✓	✗	✗	✗
MASTER-NG-2BR-C/P	✗	✗	✗	✗	✓	✗	✗	✗
MASTER-NG-200-C/P	✗	✗	✗	✗	✓	✗	✗	✗
MASTER-NG-1BR-C/P-16CA	✗	✗	✗	✗	✓	✗	✓	✗
MASTER-NG-2BR-C/P-16CA	✗	✗	✗	✗	✓	✗	✓	✗
MASTER-NG-200-C/P-16CA	✗	✗	✗	✗	✓	✗	✓	✗
MASTER-NG-1BR-C/P-32CA	✗	✗	✗	✗	✓	✗	✗	✓
MASTER-NG-2BR-C/P-32CA	✗	✗	✗	✗	✓	✗	✗	✓
MASTER-NG-200-C/P-32CA	✗	✗	✗	✗	✓	✗	✗	✓
MASTER-NG-1BR-HEPA	✗	✗	✗	✗	✗	✓	✗	✗
MASTER-NG-2BR-HEPA	✗	✗	✗	✗	✗	✓	✗	✗
MASTER-NG-200-HEPA	✗	✗	✗	✗	✗	✓	✗	✗
MASTER-NG-1BR-HEPA-16CA	✗	✗	✗	✗	✗	✓	✓	✗
MASTER-NG-2BR-HEPA-16CA	✗	✗	✗	✗	✗	✓	✓	✗
MASTER-NG-200-HEPA-16CA	✗	✗	✗	✗	✗	✓	✓	✗
MASTER-NG-1BR-HEPA-32CA	✗	✗	✗	✗	✗	✓	✗	✓
MASTER-NG-2BR-HEPA-32CA	✗	✗	✗	✗	✗	✓	✗	✓
MASTER-NG-200-HEPA-32CA	✗	✗	✗	✗	✗	✓	✗	✓

Modelli - Models - Modèles - Modelle - Modelos



MASTER-NG-2BR

MASTER-NG-200

Dimensioni - Dimensions - Dimensions - Abmessungen - Dimensiones

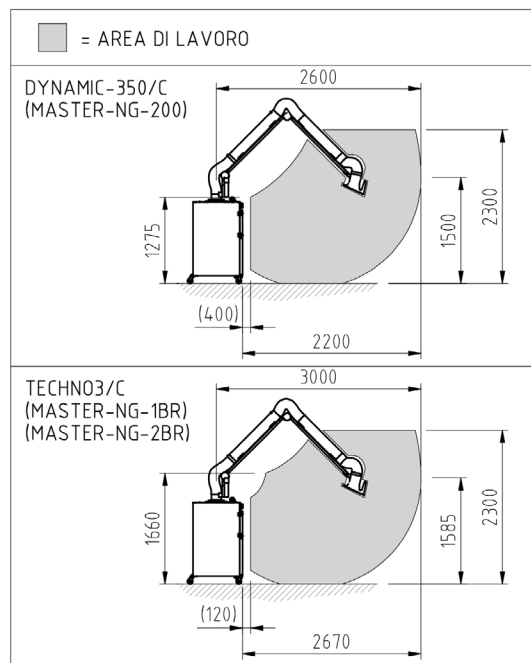
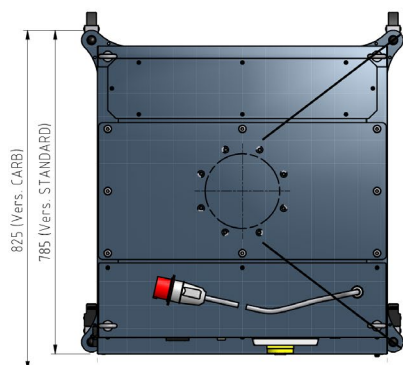
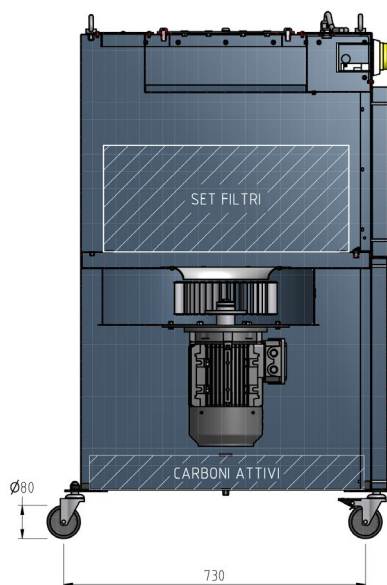
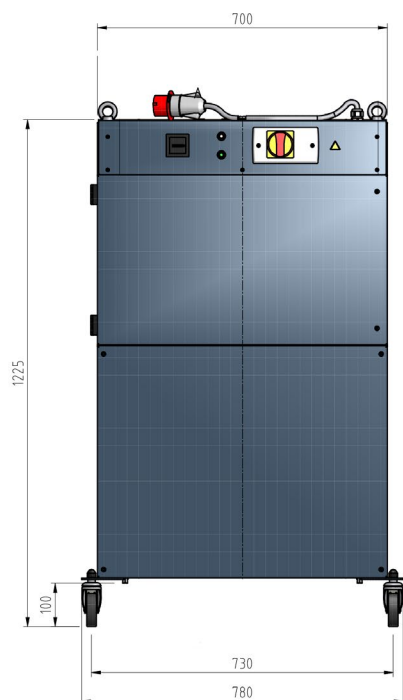

MINIJET-DF1/DF2



I nuovi filtri a cartucce orizzontali MINIJET-DF1/DF2 trovano applicazione nell'aspirazione e filtrazione di fumi di saldatura, polveri fini e grossolane, trucioli in modesta quantità. Equipaggiato di braccio Techno Ø150 L 3 mt. L'aria attraversa la precamera verticale nella quale avviene, per decantazione, la separazione della maggior parte delle polveri: quelle più pesanti si depositano sul fondo nel primo cassetto di raccolta. Il successivo labirinto e la sezione filtrante con cartucce ad alta efficienza, provvedono alla filtrazione delle polveri residue che si depositano nel secondo contenitore. L'aria viene espulsa attraverso una griglia posta sulla parte superiore. Disponibile in versione con 1 e 2 cartucce.



The MINIJET-DF1/DF2 filter units equipped with horizontal cartridges are suitable for suction and filtration of welding fumes, fine and coarse dusts as well as of small quantities of chips. Equipped with an articulated arm flanged model Techno Ø150 L 3 mt. The filter unit consists of one vertical pre-chamber, where the heaviest dusts are sorted out, as a tailing pond. The dusts can fall then in a first collecting bin. The following labyrinth together with the high efficiency filtering cartridges complete the filtration of the remaining fine dusts collecting them in the second bin. Air is exhausted out through a top grill. Version available with one or two cartridges.



Les nouveaux filtres à cartouches horizontales MINIJET-DF1/DF2 trouvent application dans l'aspiration et la filtration des fumées de soudure, poussières fines ou plus importantes, copeaux en faible quantité. Equipés d'un bras Techno 150 de 3 mt. L'air traverse la préchambre dans laquelle se produit par décantation la séparation de la majeure partie des poussières: les plus lourdes se déposent dans le premier contenant. Le suivant labyrinthe et la section de filtre à cartouches à haute efficacité assurent une filtration de la poussière résiduelle, qui est déposée dans le deuxième récipient. L'air est éjecté à travers une grille placée sur la paroi supérieure. Disponible avec 1 et 2 cartouches.



Die neuen mobilen Absauggeräte MINIJET-DF1/DF2 mit horizontalen Filterpatronen sind geeignet für die Absaugung und Filtration von Schweißrauch, groben und feinen Stäuben, sowie für geringe Mengen an Späne. Ausgestattet mit Arm Techno 150 von 3 mt. Die schadstoffbehaftete Luft wird durch einen Zentrifugalventilator im Unterdruck angesaugt und durchströmt dabei die Vorkammer, in welcher die groben Partikel bereits vorabgeschieden werden und sich im ersten Behälter ansammeln. Das folgende Labyrinth und die Filtration durch hocheffiziente Filterpatronen sorgen für die Abscheidung der restlichen Stäube, die im zweiten Behälter dekantieren. Die Luft wird durch einen Rost an der oberen Wand angeordnet ausgeworfen. Erhältlich mit 1 und 2 Patronen.



El nuevo filtro MINIJET-DF1/DF2 con cartuchos horizontales, encuentra aplicación en la aspiración y filtración de humos de soldadura, polvos finos y gruesos en cantidades limitadas. Las máquinas son completas de una conexión apta a acoplar los brazos de aspiración modelo Techno. El aire contaminado se aspira a través del brazo y decanta en una precámara vertical donde se produce una primera pre-separación de la mayor parte de los polvos que se quedan en el primer cajón de recolección. A seguir hay un laberinto y una sección de filtración con cartuchos de alta eficiencia donde se produce la filtración de los polvos residuos. Estos polvos residuos se depositan en el segundo cajón de recolección. El aire filtrado, atraviesa el ventilador de alto rendimiento, situado en la parte superior del filtro (que garantiza una elevada capacidad de aspiración con un bajo nivel de ruido) y es expulsado a través de una red situada en la parte superior. Disponible en modelos con 1 o 2 cartuchos.

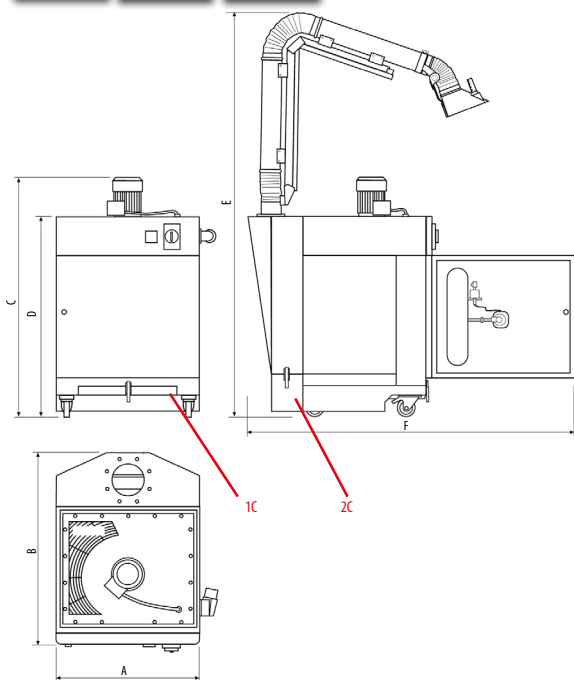
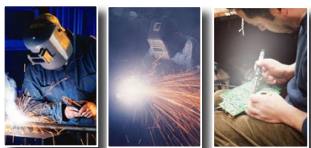

rif.	mm
A	675
B	740
C	1162
D	939
E	2360
F	1530

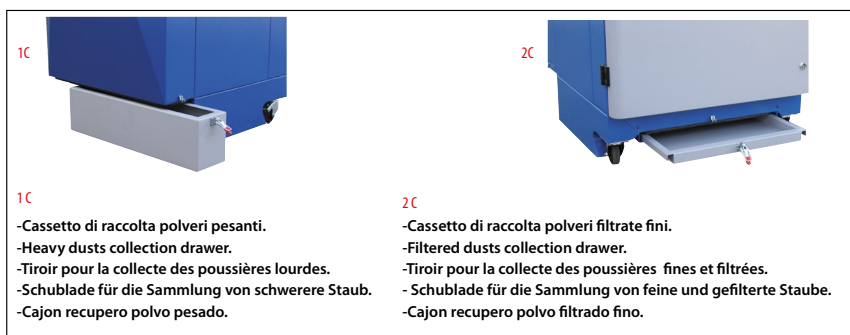

Dettagli tecnici - Technical details - Données techniques - Technische Daten - Datos Técnicos

Model	m³/h	c.f.m.	%	m²	Kg	Lbs	V	phases	Hz	cert	cart.	HP	kW
MINIJET-DF1	1100	856	99,9	8	135	297,6	400	3P+N+T	50	CE	1	1	0,75

MINIJET-DF1/DF2

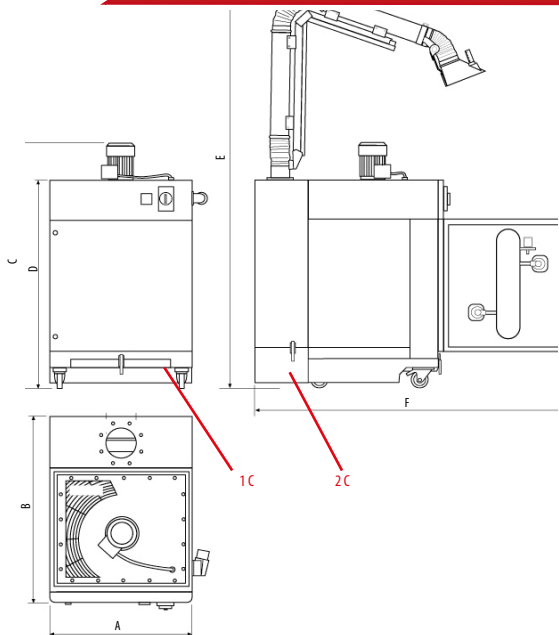

rif.	mm
A	750
B	955
C	1380
D	1158
E	2579
F	1654



OPTIONAL



- cod. PLENUM
- Plenum insonorizzato.
- Soundproof plenum.
- Plenum insonorisé.
- Plenum insonorizado.

Dettagli tecnici - Technical details - Données techniques - Technishe Daten - Datos Técnicos

Model	m ³ /h	c.f.m.	%	m ²	Kg	Lbs	V	phases	Hz	cert	cart.	HP	kW
MINIJET-DF2	1550	1109	99,9	16	170	374,8	230/400	3ph+N+T	50	CE	2	1,5	1,1

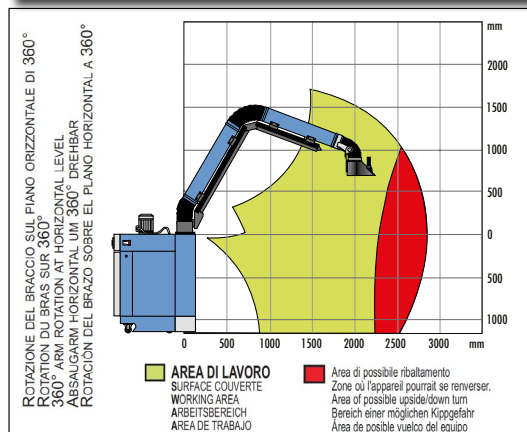
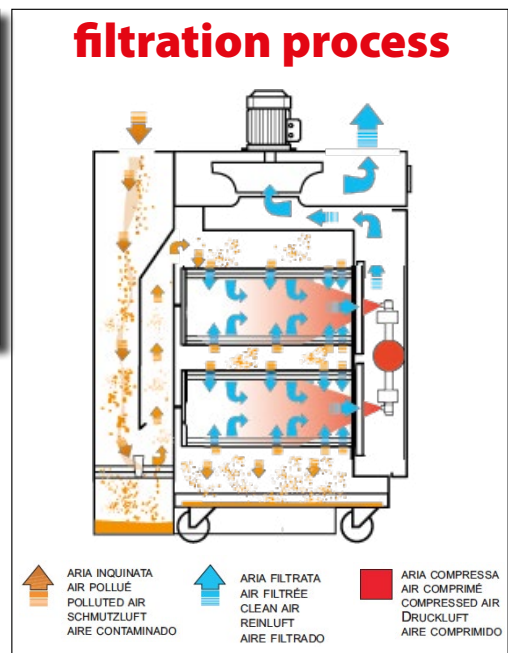

- Contatore.
- Hour meter.
- Compteur horaire.
- Stundenzähler.
- Contador de horas.



HD



I nuovi filtri a cartucce orizzontali MASTERJET-DF2 trovano applicazione nell'aspirazione e filtrazione di fumi di saldatura, polveri fini e grossolane, trucioli in modesta quantità. Equipaggiato di braccio Techno Ø150 L 3 mt. L'aria attraversa la precamera verticale nella quale avviene, per decantazione, la separazione della maggior parte delle polveri: quelle più pesanti si depositano sul fondo nel primo cassetto di raccolta. Il successivo labirinto e la sezione filtrante con cartucce ad alta efficienza, provvedono alla filtrazione delle polveri residue che si depositano nel secondo contenitore. L'aria viene espulsa attraverso una griglia posta sulla parte superiore. Disponibile in versione con 1 e 2 cartucce.



The MASTERJET-DF2 filter units equipped with horizontal cartridges are suitable for suction and filtration of welding fumes, fine and coarse dusts as well as of small quantities of chips. Equipped with an articulated arm flanged model Techno Ø150 L 3 mt. The filter unit consists of one vertical pre-chamber, where the heaviest dusts are sorted out, as a tailing pond. The dusts can falling then in a first collecting bin. The following labyrinth together with the high efficiency filtering cartridges complete the filtration of the remaining fine dusts collecting them in the second bin. Air is exhausted out through a top grill. Version available with one or two cartridges.



Les nouveaux filtres à cartouches horizontales MASTERJET-DF2 trouvent application dans l'aspiration et la filtration des fumées de soudure, poussières fines ou plus importantes, copeaux en faible quantité. Equipés d'un bras Techno 150 de 3 mt. L'air traverse la préchambre dans laquelle se produit par décantation la séparation de la majeure partie des poussières: les plus lourdes se déposent dans le premier container. Le suivant labyrinthe et la section de filtre à cartouches à haute efficacité assurent une filtration de la poussière résiduelle, qui est déposée dans le deuxième récipient. L'air est éjecté à travers une grille placée sur la paroi supérieure. Disponible avec 1 et 2 cartouches.



Die neuen mobilen Absauggeräte MASTERJET-DF2 mit horizontalen Filterpatronen sind geeignet für die Absaugung und Filtration von Schweißrauch, groben und feinen Stäuben, sowie für geringe Mengen an Späne. Ausgestattet mit Arm Techno 150 von 3 mt. Die schadstoffbehaftete Luft wird durch einen Zentrifugalventilator im Unterdruck angesaugt und durchströmt dabei die Vorkammer, in welcher die groben Partikel bereits vorabgeschieden werden und sich im ersten Behälter ansammeln. Das folgende Labyrinth und die Filtration durch hocheffiziente Filterpatronen sorgen für die Abscheidung der restlichen Stäube, die im zweiten Behälter dekantieren. Die Luft wird durch einen Rost an der oberen Wand angeordnet ausgeworfen. Erhältlich mit 1 und 2 Patronen.



El nuevo filtro MASTERJET-DF2 con cartuchos horizontales, encuentra aplicación en la aspiración y filtración de humos de soldadura, polvos finos y gruesos en cantidades limitadas. Las máquinas son completas de una conexión apta a acoplar los brazos de aspiración modelo Techno. El aire contaminado se aspira a través del brazo y decanta en una precámara vertical donde se produce una primera pre-separación de la mayor parte de los polvos que se quedan en el primer cajón de recolección. A seguir hay un laberinto y una sección de filtración con cartuchos de alta eficiencia donde se produce la filtración de los polvos residuos. Estos polvos residuos se depositan en el segundo cajón de recolección. El aire filtrado, atraviesa el ventilador de alto rendimiento, situado en la parte superior del filtro (que garantiza una elevada capacidad de aspiración con un bajo nivel de ruido) y es expulsado a través de una red situada en la parte superior. Disponible en modelos con 1 o 2 cartuchos.

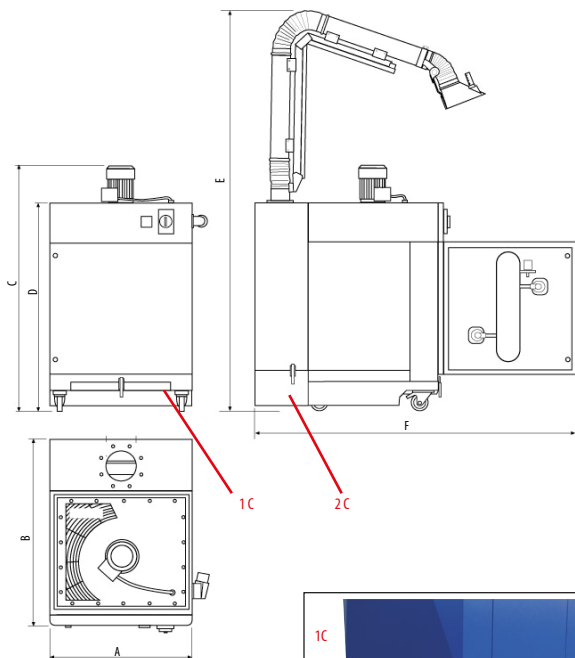

rif.	mm
A	750
B	955
C	1380
D	1158
E	2579
F	1654



- Sistema automatico di pulizia ad aria compressa.
- Pneumatic cleaning automatic system (with compressed air).
- Système automatique de décolmatage à air comprimé.
- Einer automatischen Druckluftabreinigung.
- Sistema de limpieza por medio de aire comprimido.

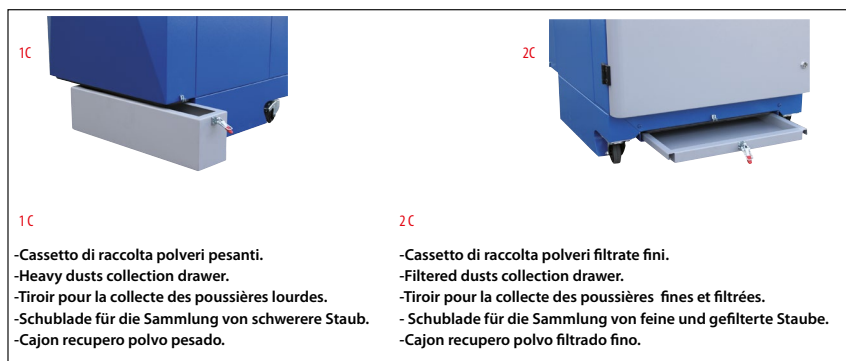

1C

- Cassetto di raccolta polveri pesanti.
- Heavy dusts collection drawer.
- Tiroir pour la collecte des poussières lourdes.
- Schublade für die Sammlung von schwerere Staub.
- Cajon recupero polvo pesado.

2C

- Cassetto di raccolta polveri filtrate fini.
- Filtered dusts collection drawer.
- Tiroir pour la collecte des poussières fines et filtrées.
- Schublade für die Sammlung von feine und gefilterte Staube.
- Cajon recupero polvo filtrado fino.

OPTIONAL



- cod. PLENUM
- Plenum insonorizzato.
- Soundproof plenum.
- Plenum insonorisé.
- Plenum insonorizado.

MASTERJET-DF2



MASTERJET-DF2-200



MASTERJET-DF2-2BR



Dettagli tecnici - Technical details - Données techniques - Technische Daten - Datos Técnicos

Model	m ³ /h	c.f.m.	%	m ²	Kg	Lbs	V	phases	Hz	cert	cart.	HP	KW
MASTERJET-DF2-1BR	1500	1345	99,9	16	185	407,9	400	3P+N+T	50	CE	2	3	2,2
MASTERJET-DF2-2BR	2500	1345	99,9	16	210	462,9	400	3P+N+T	50	CE	2	3	2,2
MASTERJET-DF2-200	2000	1345	99,9	16	190	418,8	400	3P+N+T	50	CE	2	3	2,2

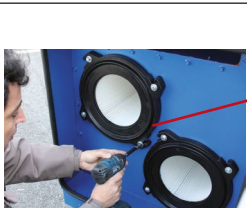

cod. DF-CART/01
Ø325 - H400 mm

**IFA/BGIA
M PES**

- Cartucce filtranti.
- Filtering cartridges.
- Cartouches filtrantes.
- Filterpatronen.
- Cartuchos filtrantes.

- Cartuccia in Poliestere.
- Polyester cartridges.
- Cartouches Polyester.
- Polyesterpatronen.
- Cartuchos filtrantes.

filtration process

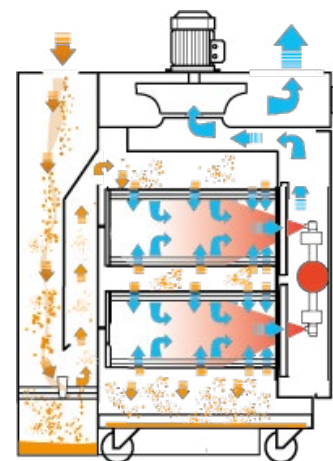

- ↑ ARIA INQUINATA
AIR POLLUÉ
POLLUTED AIR
SCHMUTZLUFT
AIRE CONTAMINADO
- ↑ ARIA FILTRATA
AIR FILTRÉE
CLEAN AIR
REINLUFT
AIRE FILTRADO
- ARIA COMPRESA
AIR COMPRIMÉ
COMPRESSED AIR
DRUCKLUFT
AIRE COMPRIMIDO

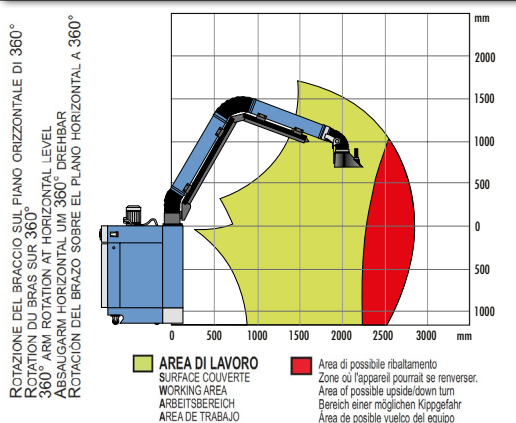

- Contatore.
- Hour meter.
- Compteur horaire.
- Stundenzähler.
- Contador de horas.