



TECNOLUX
hi-tech, hi-tools, hi-team

NEW DESIGN!



TECNOLIFTERS

NUOVA LINEA PRESSE

Una gamma sviluppata per capacità di compressione in 8 versioni diverse per soddisfare qualsiasi utilizzo «leggero» nel mondo automotive.

NEW PRESSES LINE

The line developed in 8 different configurations to satisfy any «light» use in the automotive equipment.



10
TON

15
TON

20
TON



NUEVA LÍNEA PRENSAS

Una nueva gama será desarrollada para una capacidad de compresión en 8 diferentes versiones para satisfacer cualquier uso «ligero» en el sector automoción.

NEUE PRESSELINIE

Die Linie besteht aus 8 verschiedenen Verdichtungsleistung Versionen, um jegliche "leichte" Benutzung in der Automobilwelt zu entsprechen.

20
TON

30
TON

50
TON



TECNOLUX
hi-tech, hi-tools, hi-team

TECNOLIFTERS

Name	Page
Presse idrauliche Prensas hidráulicas Hydraulic presses Hydraulische Standpressen	03
Gru idrauliche Grúas hidráulica Hydraulic cranes Hydraulische Kräne	08
Cric idraulici a carrello Gatos hidráulicos de carretilla Hydraulic trolley jacks Hydraulische Rangierheber	13
Cric da fossa Gatos hidráulicos de foso Transmission jacks Getriebeheber	14
Cavalletti Soportes Stands Montageständer	16



Code T1650-T1652B

Pressa idraulica da banco, pompa a mano a due velocità, con sistema di sicurezza idraulico in caso di sovraccarico, ritorno automatico del pistone, completa di una serie di prismi V.

Caratteristiche Tecniche: pompa a due velocità. Sicurezza idraulica in caso di sovraccarico. Ritorno automatico del pistone. Stelo cromato. Manometro. Serie di prismi a V.

Pressa hidráulica de mesa con bomba manual, doble velocidad, válvula de seguridad contra sobrecargas, pistón con retorno automático, apoyos en V.

Características técnicas: bomba doble velocidad. Válvula de seguridad contra sobrecarga, pistón retorno automático, apoyos en V.

Sistema automático de vuelta del brazo. Barra plateada cromo. Manómetro.

Hydraulic workbench press equipped with a two-speed manual pump, over load safety valve, arm automatic back-run system, V blocks.

Technical features: two speed pump. Overload safety-valve. Automatic return of the arm. Chromium plated rod. Pressure gauge. V blocks.

Hydraulische Werkbankpresse mit zweistufiger Manualpumpe, Überlastungsicherung, automatischem Kolbenrücklauf und V Prismen.

Technische Eigenschaften: Pumpe 2-stufig. UL-Sicherheitsventil. Automatischer Rücklauf des Kolbens. Verchromte Pratze. Manometer. Auflageblöcke in V-Form.

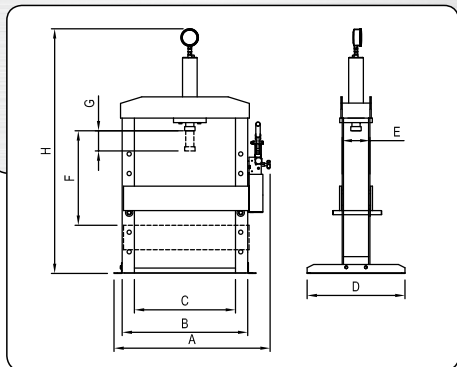

	T1650	T1652B
A	830	830
B	690	690
C	530	550
D	500	500
E	125	125
F-	100	100
F+	480	480
G	150	150
H	1030	1030
M	310	310
kg	100	110

- Presse idrauliche • Prensa hidráulicas
- Hydraulic presses • Hydraulische Standpressen

Code T1650: 10 TONS
Code T1652B: 15 TONS

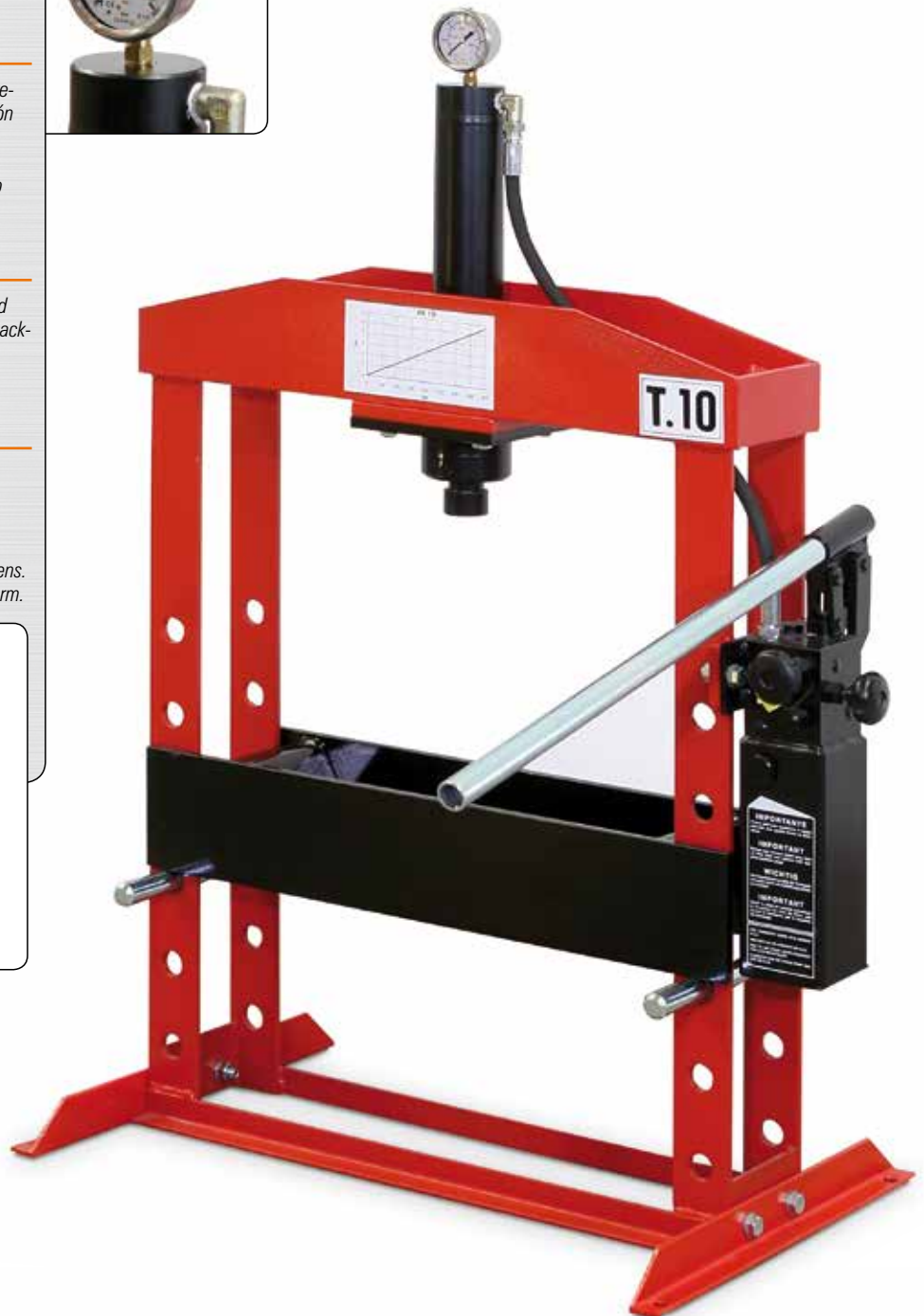



Code **T1715CS**
Code **T1720CS**

Pressa idraulica a colonna, pompa a mano a due velocità, con sistema di sicurezza idraulico in caso di sovraccarico, ritorno automatico del pistone, completa di una serie di prismi a V, manometro.

Pressa hidráulica con bomba manual doble velocidad, válvula de seguridad contra sobrecargas, pistón con retorno automático, apoyos en V incluidos.

Hydraulic press equipped with a two-speed manual pump, over load safety valve, arm automatic back-run system, V blocks. Pressure gauge.

Hydraulische Standpresse mit zweistufiger Manualpumpe, Überlastungssicherung, automatischem Kolbenrücklauf und V Prismen. Sicherheitsventil. Manometer. Auflageblöcke in V-Form.

- **Presse idrauliche** • Prensa hidráulicas
- **Hydraulic presses** • Hydraulische Standpressen



- **Ritorno automatico del pistone. Pistone regolabile.**
- **Sistema automático de retorno del pistón**
- **Arm automatic back-run system**
- **Automatischer Rücklauf des Kolbens**

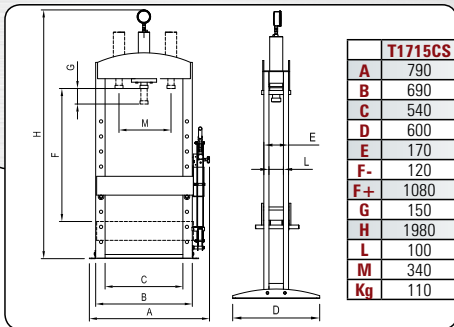
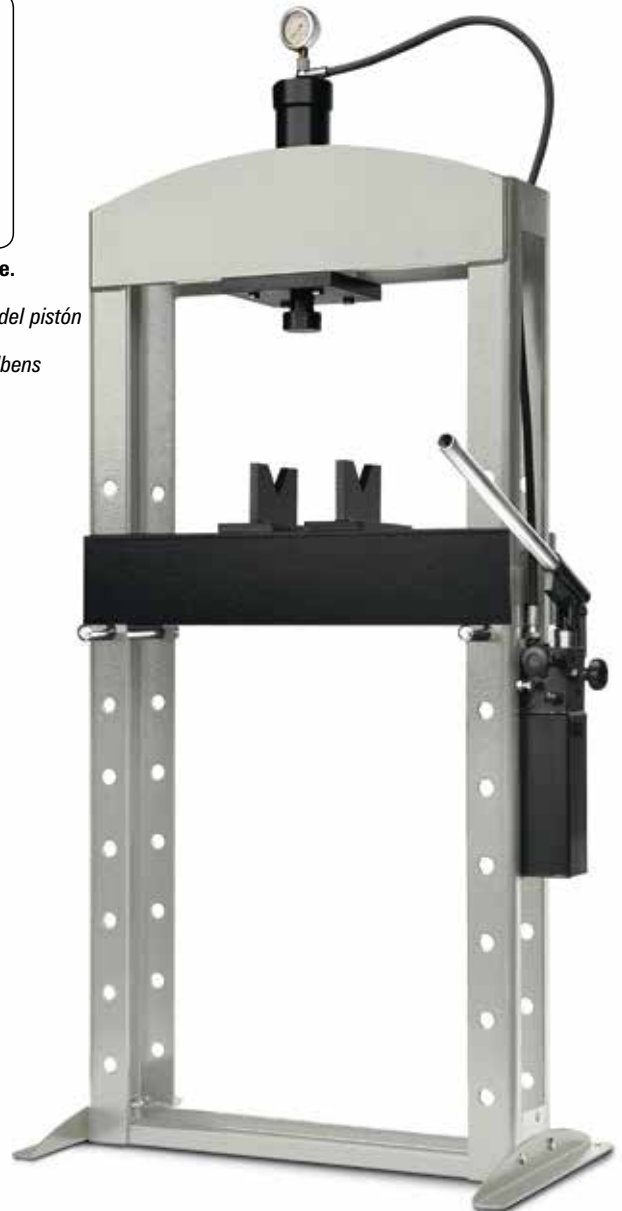

- **Pompa a due velocità**
- **Bomba doble velocidad**
- **Two-speed manual pump**
- **Doppel Effekt Pumpe**
- **Prismi**
- **Apoyos en V**
- **V blocks**
- **V Form Auflageblöcke**
- **Manometro**
- **Manómetro**
- **Pressure gauge**
- **Manometer**

Accessori • Accesorios • Accessories • Zubehören

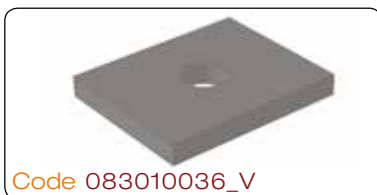

- **Piastra cacciaspine 15-20 ton**
- **Placa botadores**
- **Press plate**
- **Abdrückplatte**



- **Scatola portaoggetti 15-20 tons zincata**
- **Bandeja galvanizada para 15-20 tons**
- **Galvanised tray for 15-20 tons**
- **Verzinkte Fach für 15-20 Tons**



- **Punzoni e riduttore per 15-20 tons**
- **Mandrios y adaptador para 15-20 tons**
- **Plugs and reducer for 15-20 tons**
- **Punches und Adapter für 15-20 Tons**

Code T1715CS: 15 TONS
Code T1720CS: 20 TONS



Code **T1715**
Code **T1720**

Pressa idraulica a colonna, pompa a mano e pompa a pedale a due velocità, con sistema di sicurezza idraulico in caso di sovraccarico, ritorno automatico del pistone, completa di una serie di prismi V. Manometro.

Pressa hidráulica con bomba manual y pedal a doble velocidad, válvula de seguridad contra sobrecargas, pistón con retorno automático, Apoyos en V incluidos. Manómetro.

Hydraulic press equipped with a two-speed manual & pedal pump, over load safety valve, arm automatic back-run system, V blocks. Automatic return of the arm. Pressure gauge.

Hydraulische Standpresse mit zweistufiger Manual- und Fußpumpe, Überlastungsicherung, automatischem Kolbenrücklauf und V Prismen. Sicherheitsventil. Manometer.

- **Presse idrauliche** • Prensa hidráulicas
- **Hydraulic presses** • Hydraulische Standpressen



- **Ritorno automatico del pistone.**
Pistone regolabile.
- **Sistema automático de retorno del pistón**
- **Arm automatic back-run system**
- **Automatischer Rücklauf des Kolbens**

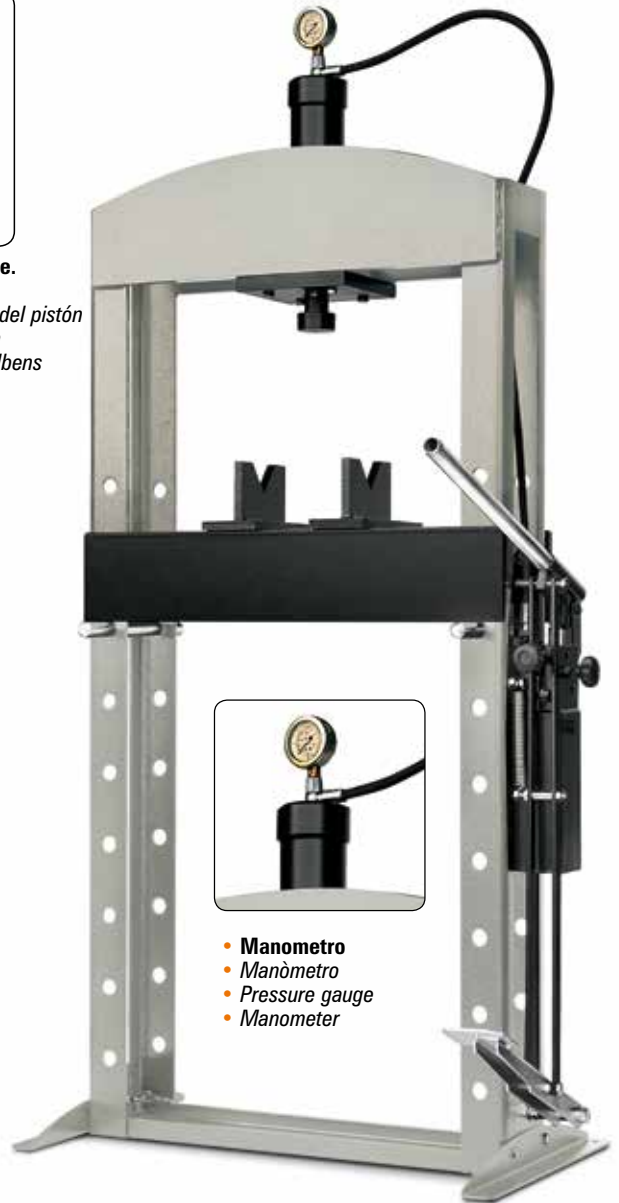

- **Manometro**
- **Manómetro**
- **Pressure gauge**
- **Manometer**

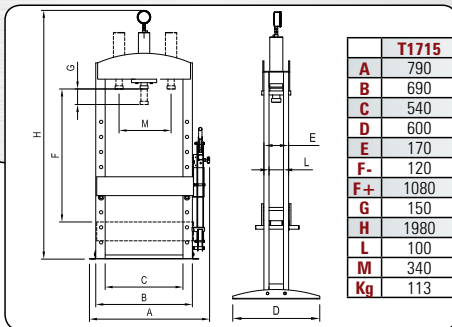

	T1715	T1720
A	790	960
B	690	770
C	540	620
D	600	600
E	170	170
F-	120	100
F+	1080	1060
G	150	150
H	1980	1980
L	100	100
M	340	420
Kg	113	114



- **Pompa a due velocità a pedale**
- **Bomba doble velocidad a pedal**
- **Two-speed pedal pump**
- **Doppel Effekt Fußpumpe**

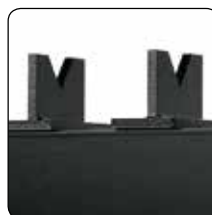

- **Prismi**
- **Apoyos en V**
- **V blocks**
- **V Form Auflageblöcke**

Accessori • Accesorios • Accessories • Zubehören

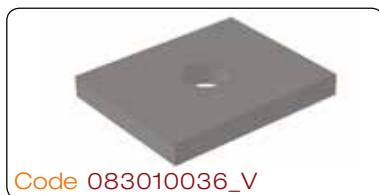

Code 083010036_V

- **Piastra cacciaspina 15-20 ton**
- **Placa botadores**
- **Press plate**
- **Abdrückplatte**



Code 083010031

- **Scatola portaoggetti 15-20 tons zincata**
- **Bandeja galvanizada para 15-20 tons**
- **Galvanised tray for 15-20 tons**
- **Verzinkte Fach für 15-20 Tons**



Code 083999057: 15 TONS
Code 083999058: 20 TONS

- **Punzoni e riduttore per 15-20 tons**
- **Mandrinis y adaptador para 15-20 tons**
- **Plugs and reducer for 15-20 tons**
- **Punches und Adapter für 15-20 Tons**

Code T1715: 15 TONS
Code T1720: 20 TONS



Code **T1730CS**
Code **T1750CS**

Pressa idraulica a colonna, pompa a mano a due velocità, con argano e sistema di sicurezza idraulico in caso di sovraccarico, ritorno automatico del pistone, completa di una serie di prismi V. Manometro.

Pressa hidráulica con cabrestante, bomba manual doble velocidad, válvula de seguridad contra sobrecargas, pistón con retorno automático, Apoyos en V incluidos. Manómetro.

Hydraulic press equipped with lifting winch, two-speed manual pump, over load safety valve, arm automatic back-run system, V blocks. Pressure gauge.

Hydraulische Standpresse mit Hubwinde, zweistufiger Manualpumpe, Überlastungsicherung, automatischem Kolbenrücklauf und V Prismen. Manometer. Auflegeblöcke in V-Form.

- **Presse idrauliche** • Prensa hidráulicas
- **Hydraulic presses** • Hydraulische Standpressen



- **Ritorno automatico del pistone. Pistone regolabile.**
- **Sistema automático de retorno del pistón**
- **Arm automatic back-run system**
- **Automatischer Rücklauf des Kolbens**

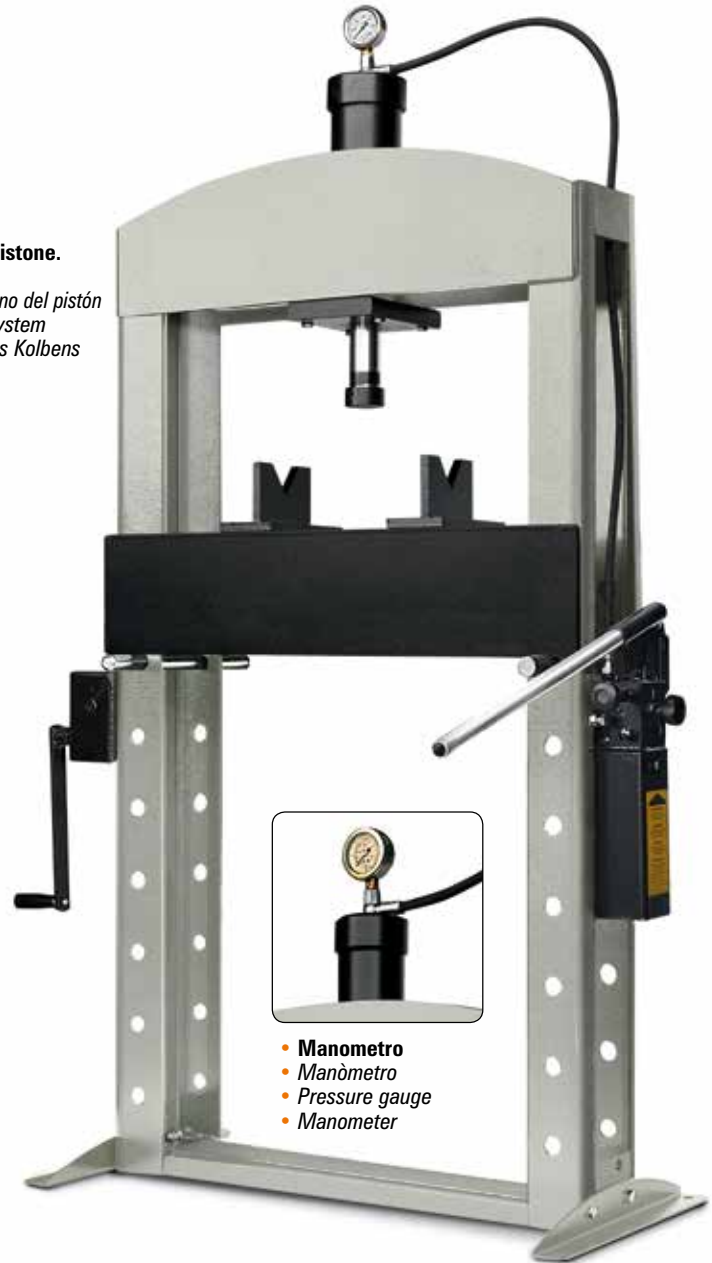

- **Manometro**
- **Manómetro**
- **Pressure gauge**
- **Manometer**

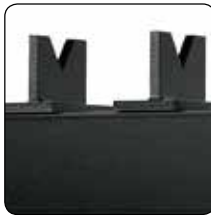
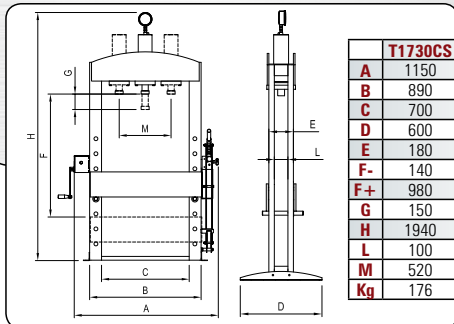

- **Pompa a due velocità**
- **Bomba doble velocidad**
- **Two-speed manual pump**
- **Doppel Effekt Pumpe**
- **Prismi**
- **Apoyos en V**
- **V blocks**
- **V-Form Auflegeblöcke**
- **Argano**
- **Cabrestante**
- **Lifting winch**
- **Hubwinde**

Accessori • Accesorios • Accessories • Zubehören



- **Punzoni e riduttore per 30-50 tons**
- **Mandrinos y adaptador para 30-50 tons**
- **Plugs and reducer for 30-50 tons**
- **Punches und Adapter für 30-50 Tons**

Code T1730CS: 30 TONS
Code T1750CS: 50 TONS



Code **T1730**
Code **T1750**

Pressa idraulica a colonna, pompa a mano e pedale a due velocità, con argano e sistema di sicurezza idraulico in caso di sovraccarico, ritorno automatico del pistone, completa di una serie di prismi V. Manometro.

Pressa hidráulica con cabrestante, bomba manual y pedal doble velocidad, válvula de seguridad contra sobrecargas, pistón con retorno automático. Apoyos en V incluidos. Manómetro.

Hydraulic press equipped with lifting winch, two speed manual/pedal pump, over load safety valve, arm automatic back run system, V blocks. Pressure gauge.

Hydraulische Standpresse mit Hubwinde, zweistufiger Manual- und Fußpumpe, Überlastungsicherung, automatischem Kolbenrücklauf und V Prismen. Sicherheitsventil. Automatischer Rücklauf des Kolbens. Manometer. Auflegeblöcke in V Form.

- **Presse idrauliche** • Prensa hidráulicas
- Hydraulic presses • Hydraulische Standpressen



- **Ritorno automatico del pistone.**
Pistone regolabile.
- Sistema automático de retorno del pistón
- Arm automatic back-run system
- Automatischer Rücklauf des Kolbens

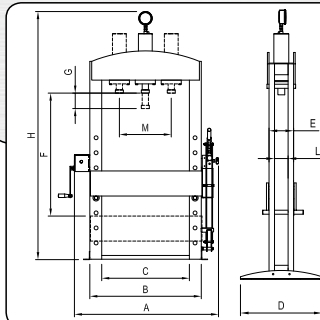

	T1730	T1750
A	1150	1210
B	890	950
C	700	710
D	600	600
E	180	200
F-	140	290
F+	980	1040
G	150	150
H	1940	2100
L	100	88
M	520	510
Kg	179	320



- **Pompa a due velocità a pedale**
- *Bomba doble velocidad a pedal*
- *Two-speed pedal pump*
- *Doppel Effekt Fußpumpe*

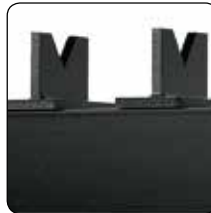

- **Prismi**
- *Apoyos en V*
- *V blocks*
- *V Form Auflegeblöcke*

Accessori • Accesorios • Accessories • Zubehören



Code 083999059: 30 TONS
Code 083999060: 50 TONS

- **Punzoni e riduttore per 30-50 tons**
- *Mandrilos y adaptador para 30-50 tons*
- *Plugs and reducer for 30-50 tons*
- *Punches und Adapter für 30-50 Tons*

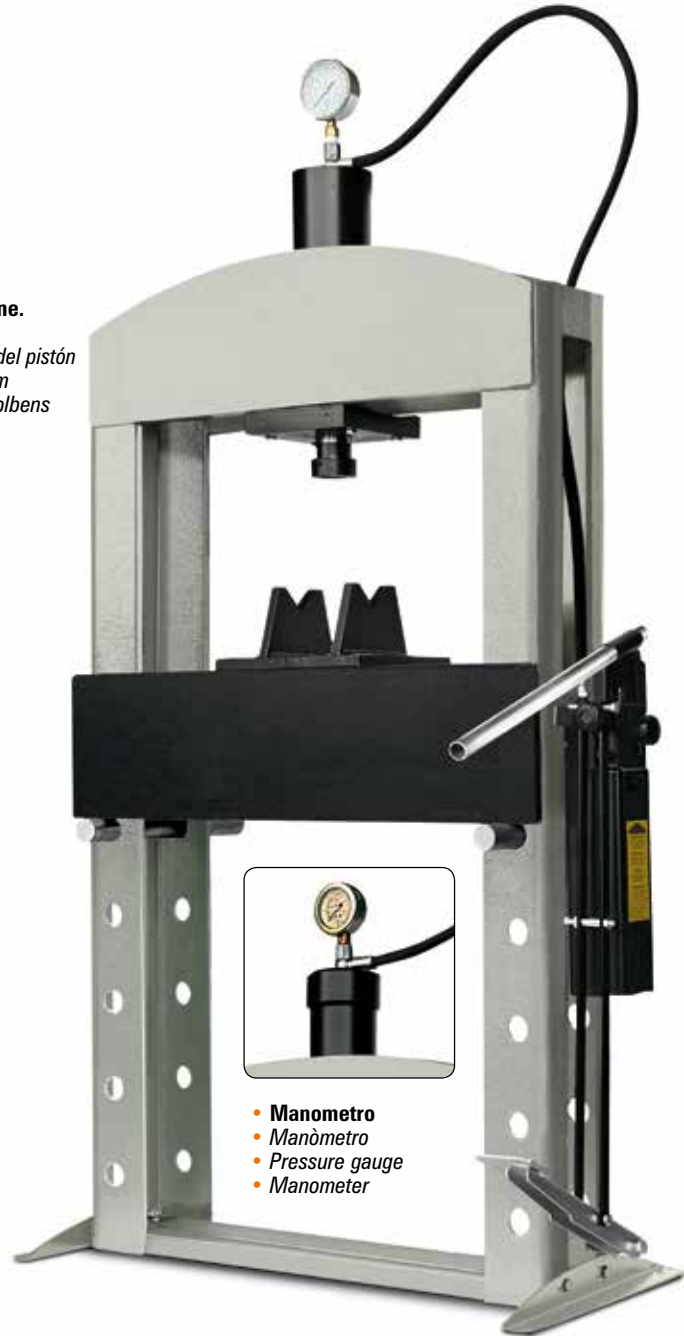

- **Manometro**
- *Manómetro*
- *Pressure gauge*
- *Manometer*

Code T1730: 30 TONS
Code T1750: 50 TONS